



SOUTH AFRICA

FINANCIAL SECTOR ASSESSMENT PROGRAM

June 2022

TECHNICAL NOTE ON SYSTEMIC RISK OVERSIGHT AND MACROPRUDENTIAL POLICY

This technical note on Systemic Risk Oversight and Macroprudential Policy was prepared by a staff team of the International Monetary Fund in the context of a joint IMF-World Bank Financial Sector Assessment Program (FSAP). It is based on the information available at the time it was completed in June 2021.

Copies of this report are available to the public from

International Monetary Fund • Publication Services
PO Box 92780 • Washington, D.C. 20090
Telephone: (202) 623-7430 • Fax: (202) 623-7201
E-mail: publications@imf.org Web: <http://www.imf.org>
Price: \$18.00 per printed copy

International Monetary Fund
Washington, D.C.



SOUTH AFRICA

FINANCIAL SECTOR ASSESSMENT PROGRAM

June 2, 2022

TECHNICAL NOTE

SYSTEMIC RISK OVERSIGHT AND MACROPRUDENTIAL POLICY

Prepared By
**Monetary and Capital Markets
Department**

This Technical Note was prepared in the context of the Financial Sector Assessment Program in South Africa during June 2021 mission led by Jennifer Elliott, IMF and Eva Gutierrez, World Bank and overseen by the Monetary and Capital Markets Department, International Monetary Fund, and the Finance, Competitiveness and Innovation Global Practice, World Bank. It contains technical analysis and detailed information underpinning the FSAP's findings and recommendations. Further information on the FSAP can be found at <http://www.imf.org/external/np/fsap/fssa.aspx>

CONTENTS

Glossary	3
EXECUTIVE SUMMARY	4
INTRODUCTION	5
INSTITUTIONAL FRAMEWORK	5
A. Willingness to Act	6
B. Ability to Act	8
C. Coordination and Cooperation	10
D. Recommendations	10
SYSTEMIC RISK MONITORING	11
A. Systemic Risk Monitoring Framework	11
B. Recommendations	11
THE MACROPRUDENTIAL TOOLKIT	13
A. Measures to Address the Sovereign-Financial Nexus	15
B. Borrower-Based Tools	18
C. Recommendations	19
FIGURES	
1. Institutional Arrangements for Macroprudential Policy	9
2. Systemic Risk Monitoring	13
3. Macroprudential Policy Actions, Credit Developments, and Tools	15
4. The Sovereign-Financial Nexus	16
TABLE	
1. Key Recommendations on Systemic Risk Oversight and Macroprudential Policy	5
ANNEX	
I. Macroprudential Policy Measures in Place	20

Glossary

BCBS	Basel Committee on Banking Supervision
BIS	Bank for International Settlements
CCB	Capital Conservation Buffer
CCyB	Counter Cyclical Capital Buffer
CEO	Chief Executive Officer
CET1	Common Equity Tier 1 Capital Ratio
CFM	Capital Flow Management Measures
CRD IV	Capital Requirement Directive IV
DSIB	Domestically Systemically Important Bank
DTI	Debt-to-Income Ratio
DSTI	Debt Service to Income Ratio
EME	Emerging Market Economies
FIC	Financial Integrity Centre
FSAP	Financial Sector Assessment Program
FSCA	Financial Sector Conduct Authority
FSCF	Financial Sector Contingency Forum
FSB	Financial Stability Board
FSC	Financial Stability Committee
FSOC	Financial Stability Oversight Committee
FSR	Financial Sector Regulation
GDP	Gross Domestic Product
HQLA	High-Quality Liquid Assets
iMaPP	Integrated Macroprudential Policy
IMF	International Monetary Fund
IRB	Internal Ratings-Based
LCR	Liquidity Coverage Ratio
LTI	Loan to Income
LTV	Loan-to-Value Ratio
MPC	Monetary Policy Committee
MPM	Macroprudential Policy Measure
MoU	Memorandum of Understanding
NBFI	Non-Bank Financial Institutions
NCR	National Credit Regulator
NPL	Non-Performing Loan
NSFR	Net Stable Funding Ratio
NT	National Treasury
PA	Prudential Authority
RW	Risk Weights
SGN	Staff Guidance Note
SIFI	Systemically Important Institution
SME	Small-to-Medium Enterprises
SRB	Systemic Risk Buffer

EXECUTIVE SUMMARY¹

South Africa has made significant progress in strengthening its macroprudential policy framework and foundations since the 2014 FSAP. Institutional arrangements were overhauled by the 2017 Financial Sector Regulations Act that, among others, introduced the current ‘Twin Peaks’ structure, provided SARB with a strong financial stability mandate, and sought to foster interagency coordination and collaboration (including via the establishment of the Financial System Council of Regulators). As a result, South Africa has a hybrid macroprudential policy framework that combines a ‘strong’ decision maker in the SARB Governor, but that is importantly supported by an advisory committee structure, fostering effective cooperation and coordination. Systemic risk monitoring has also been enhanced and some macroprudential policy tools phased-in.

SARB’s macroprudential powers could usefully be strengthened, important data gaps closed, and the toolkit broadened. SARB’s macroprudential authority is predominantly over systematically important financial institutions (SIFIs), creating a risk that targeted activities and risks will migrate outside of SIFIs. Further, the Governor must declare a ‘systemic event’ to attain more wide-ranging hard powers, which creates incentives for policy actions to be taken too late or not at all. Hence, it is important to ensure that SARB has sufficient authority, if needed going beyond the SIFIs, and reconsider the need to declare an event as a systemic event. Closing data gaps, in particular with regard to micro-level data on borrowers, would also further strengthen risk analysis and guide calibration of new tools.

South Africa stands out from peers as having a narrow toolkit and considerations to broaden it, already underway, should be continued, in particular, measures to address the sovereign-financial (bank) nexus and borrower-based tools. Addressing the sovereign-financial nexus is particularly challenging, and in that regards South Africa is far from being alone. Fiscal consolidation is likely to have to be key in reducing the sovereign risk in the financial sector, but prudential policies can play an important complementary role. Any prudential measure that could be considered to address the nexus should be mindful of other prudential requirements and the broader need for financial institutions to hold government bonds. Similarly, any measure would need to be mindful of the importance of safeguarding the smooth function of the government bond market and banks’ liquidity and profitability. Hence, prudential measures should aim at (i) ensuring resilience through increased loss absorbing capacity and (ii) provide disincentives against excessive concentration of sovereign risk, while at the same time (iii) avoiding unintended side-effects. Various measures can be considered, but regardless, they would need to be phased-in, be carefully calibrated, and clearly communicated. Efforts to prepare for the use of borrower-based tools should continue and various design features can be considered to achieve a more beneficial cost-benefit trade-off and take country-specific circumstances into account.

¹ This Technical Note was prepared by T. Tjoervi Olafsson (MCM).

Table 1. South Africa: Key Recommendations on Systemic Risk Oversight and Macroprudential Policy

Table 1. South Africa: Key Recommendations on Systemic Risk Oversight and Macroprudential Policy		
<i>Institutional Arrangements for Macroprudential Policy</i>		
Ensure that SARB has adequate powers—if needed extending beyond the systematically important financial institutions—and for the need to declare an event as systemic to attain more wide-ranging powers to be reconsidered.	SARB, Parliament	ST
The FSC could consider publishing a short record of its meeting, in particular when the Financial Stability Review is not being published, to further enhance transparency.	SARB	I
<i>Systemic Risk Monitoring</i>		
Continue the important work on developing a credit registry to facilitate risk analysis and calibration of macroprudential tools.	SARB, NCR, NT	MT
<i>Toolkit</i>		
Consider carefully calibrated prudential measures to address the sovereign-financial nexus.	SARB	ST
Continue preparations to use borrower-based tools and consider design features that could allow for a more beneficial cost-benefit tradeoffs.	SARB, NCR	MT
1 I—immediate: within one year; ST—short-term: one to three years; MT—medium-term: three-five years.		

INTRODUCTION

1. This Technical Note discusses systemic risk oversight and macroprudential policy in South Africa, in the context of the 2021 FSAP. Since the 2014 FSAP considerable progress has been made in strengthening the institutional arrangements to safeguard financial stability, systemic risk monitoring has been enhanced (including through stress tests as advised in the 2014 FSAP), and macroprudential tools—in particular Basel III tools—have been phased-in.

2. This note is structured as follows: Section I assesses the institutional framework for macroprudential policy, Section II focused on the systemic monitoring framework and data gaps, and Section III assesses the adequacy of the macroprudential toolkit, with special emphasis on tools to address the sovereign-financial nexus and borrower-based tools.

INSTITUTIONAL FRAMEWORK

3. Strong institutional arrangements for macroprudential policymaking are vital to ensure that it can be effective. The institutional framework should promote the *willingness to act* and thereby overcome the underlying policy inaction bias that results from the cost of policy actions being earlier and more easily observable than their potential benefits. The arrangement should also foster the *ability to act* to increase the resilience of the financial system and mitigate systemic risk. Finally, the framework needs to promote *effective cooperation and coordination* between institutions with a financial stability mandate. This section evaluates the current institutional arrangement in South Africa against these desired characteristics, which are set out in [the 2014 IMF Staff Guidance Note on Macroprudential Policy](#).

A. Willingness to Act

4. International experience has shown that certain institutional aspects can foster strong willingness to act ([IMF-Bank for International Settlements \(BIS\)-Financial Stability Board \(FSB\), 2016](#)). In particular, clear assignment of the macroprudential mandate, well-defined objectives for institutions involved in safeguarding financial stability, a strong role for the central bank, dedicated financial stability units, and adequate accountability and communication frameworks can all foster willingness to act and thereby overcome the inaction bias.

5. These institutional features are in place in South Africa. The Financial Sector Regulation (FSR) Act 9 of 2017 defined key features of the institutional framework, which are then further elaborated on in a policy framework agreed between the Minister of Finance and the Governor. The FSR Act established a strong mandate for the SARB to protect and enhance financial stability and restoring financial stability in case a systemic event has occurred. Hence, the SARB plays a pivotal role in the institutional framework for macroprudential policy, with the Governor serving as the key decision-maker, backed by external and internal advisory committees. Other financial regulators also have a financial stability mandate (or at least a role to assist in maintaining financial stability), resulting in South Africa having more than one macroprudential authority, albeit SARB plays a leading role.

6. The combination of a designated decision maker and advisory committee structure with clear financial stability mandates is likely to foster willingness to act. Given the leading position of the Governor in the institutional arrangements, a key concern—albeit not one that has materialized—is that at some point an individual with a strong inaction bias (or overly aggressive action preferences) would be appointed. Hence, it is important that the FSR Act set up two external advisory committees, which have clear mandates and advise the Governor on macroprudential policy, complementing the longer-standing internal Financial Stability Committee (Figure 1, top panel):

- **The Financial Stability Oversight Committee (FSOC)** is a Statutory Committee under the FSR Act and advises the Governor of the SARB on matters relating to financial stability. FSOC's primary objectives are to: (a) support the SARB when it performs its functions in relation to financial stability; and (b) facilitate cooperation and collaboration between the SARB and other financial sector regulators. It includes representatives from the SARB, NT and all financial regulators. The committee consists of the Governor as Chairperson, the Deputy Governor responsible for financial stability matters, the Chief Executive Officer (CEO) of the Prudential Authority (PA), the Commissioner of the Financial Sector Conduct Authority (FSCA), the CEO of the National Credit Regulator (NCR), the Director-General of NT, the Director of the Financial Intelligence Centre (FIC), and up to three additional officials of the SARB appointed by the Governor. Normally, it meets biannually.
- **The Financial Sector Contingency Forum (FSCF)** is a statutory forum established by the Governor of the SARB to assist the FSOC with identifying risks that could lead to a systemic event; and coordinating plans, mechanisms and structures to mitigate those risks. The FSCF

was created to ensure broad participation and engagement of stakeholder groups in defining and coordinating approaches to crisis management. The forum does not play an active role in managing systemic events. Rather, it supports the development and testing of contingency plans and works as an established network for coordinating interventions and communicating effectively during a systemic event. The forum was established by the Governor. It consists of a Deputy Governor as the Chairperson (designated by the Governor), representatives from each financial sector regulator, representatives from other organs of state and representatives from financial sector associations.

- **The Financial Stability Committee (FSC)** is an internal SARB committee which was established in 2000 and restructured and elevated in 2010 in terms of its membership and responsibilities. The purpose of the FSC is to formulate financial stability policy on behalf of the SARB in support of its mandate. The FSC comprises the Governor as Chairperson—who cannot be outvoted in the committee—the Deputy Governors, all members of the Monetary Policy Committee (MPC) and a maximum of seven other SARB officials. The SARB fulfils its responsibility to monitor and review the strengths and weaknesses of the financial system and any risks to financial stability, and take the necessary steps to mitigate these risks, through the FSC. The FSC meets four times a year, or as required, to monitor vulnerabilities in the global and domestic environments, assess their possible implications for domestic financial stability and decide whether any mitigating measures need to be taken. The content and discussions at FSC meetings are shared with the FSOC while the issues discussed by the FSC and any decisions taken are communicated in the biannual *Financial Stability Review* publication. Records of FSC meetings are not published.

7. This wide-ranging committee structure is what sets the South African institutional arrangements apart from many other emerging market economies (EMEs), but as noted above, when it is combined with a designated sole decision maker it should be a source of strength (Figure 1, lower panel). Furthermore, as noted below, it also has the benefit of supporting effective cooperation and coordination.

8. The Financial Stability Review serves as a key communication and accountability vehicle, with clear requirements set out in the FSR Act, which also should foster willingness to act. The Financial Stability Review must, at least biannually, set out: (a) SARB's assessment of financial stability in the period under review; (b) its identification and assessment of the risks and vulnerabilities to financial stability in at least the next 12 months; (c) an overview of steps taken by it and the financial sector regulators to identify and manage risks, weaknesses or disruptions in the financial system during the period under review and that are envisaged to be taken during at least the next 12 months; and (d) an overview of recommendations made by it and the FSOC during the period under review and progress made in implementing those recommendations.² As such it serves as an effective assessment of risks and as a tool to communicate clearly on those and the policies taken to alleviate them.

² The Minister of Finance and the FSOC shall have two weeks to comment on the Review before its publication.

9. The FSC does not provide a summary of its meetings, except what is included in the Financial Stability Review. As the FSC meets four times a year and the Review is only published biannually, it implies that no information about the FSC's assessment of risks or need for policy action is published every other time it meets.

B. Ability to Act

10. Willingness to act is of limited use if not combined with powers to take action to mitigate systemic risk, as well as strong institutional capacity and influence. Those powers can be of a different type and also vary in terms of strength. In particular, they can refer to powers to collect information and close data gaps, determine the design and calibration of regulatory constraints, and powers to designate SIFIs and initiate changes in the regulatory perimeter to address leakages where financial intermediation migrates outside of the perimeter. In terms of strength, powers can be 'hard' (direct control), 'semi-hard' (recommendations with a 'comply or explain' mechanism), or 'soft' (express opinion without need for follow-up by other agencies). Institutional capacity and influence involve having the resources to assess when action is needed and the status, going beyond in legal terms, to overcome potential resistance against needed policy actions.

11. The SARB's powers are somewhat constrained outside of declared systemic events, being mostly confined to designating SIFIs and setting macroprudential policy constraints on SIFIs, but SARB remains a strong institution which strengthens its overall ability to act. The Governor designates which financial institutions are SIFIs, after having consulted the FSOC. This decision must take into account, among other things, the size, complexity, interconnectedness, and substitutability of the institution in question. Based on this designation, the SARB can direct the PA, after having consulted with it, to impose various types of macroprudential regulations on SIFIs. These include capital and liquidity tools (including a countercyclical capital buffer, CCyB, which, different from other macroprudential tools, would apply to all banks, not just SIFIs), but also a broader set of constraints (Article 30 in the FSR Act). The SARB may also advise other financial regulators, and any organ of state, to take steps to mitigate risks, but without any 'comply-or-explain' mechanism attached to it. The SARB's advice may carry extra weight due to its credibility in South Africa.

12. To attain a wider range of powers, the Governor needs to declare an event as a 'systemic event'. The FSR Act gives the Governor, after having consulted the Minister of Finance and potentially the FSOC, the power to declare that a specific event or circumstances is a 'systemic event', regardless of whether they have already taken place or not or are considered imminent. Following such a declaration, the SARB "must take all reasonable steps" to mitigate the risk and safeguard financial stability. If such a declaration is made, all financial sector regulators must provide the SARB with any relevant information and consult the SARB before exercising their own regulatory powers. In the case where a systemic event has already occurred or is imminent, the SARB in effect attains authority over regulators' directives to address the event (explicitly in the case of the PA, FSCA, and the FIC).³

³ For instance, following a declaration of a systemic event, SARB could issue regulatory instruments on capital requirements, loan restrictions, or liquidity on non-SIFI, which it cannot do in normal times.

Figure 1. South Africa: Institutional Arrangements for Macroprudential Policy¹

The SARB Governor is the main decision maker on macroprudential policy, but is supported by internal and external committees as well as other institutions with financial stability mandates.

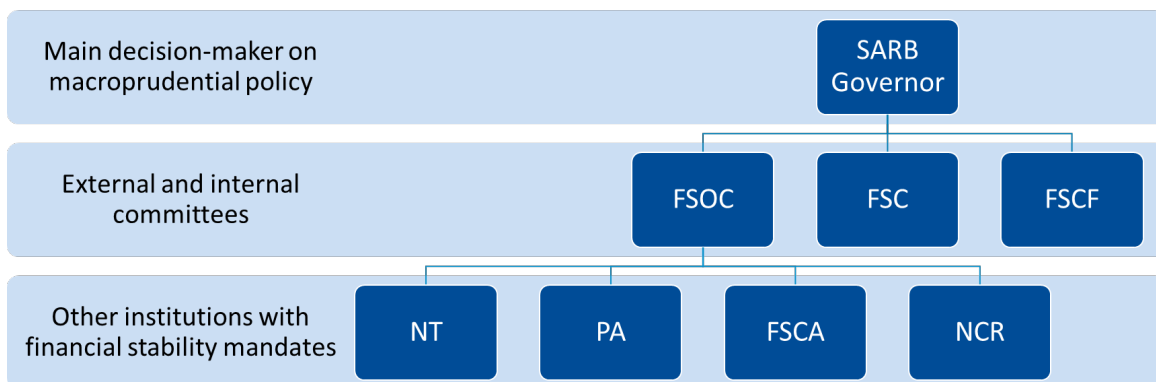

Given the number of authorities and committees with financial stability mandates (or a role to assist in maintaining it), South Africa falls into the category of EMEs that have a so-called 'hybrid' model (combining models 1-3).

Institutional Arrangements for Macroprudential Policy
(Number of EMDEs, Share of 86 EMDEs)

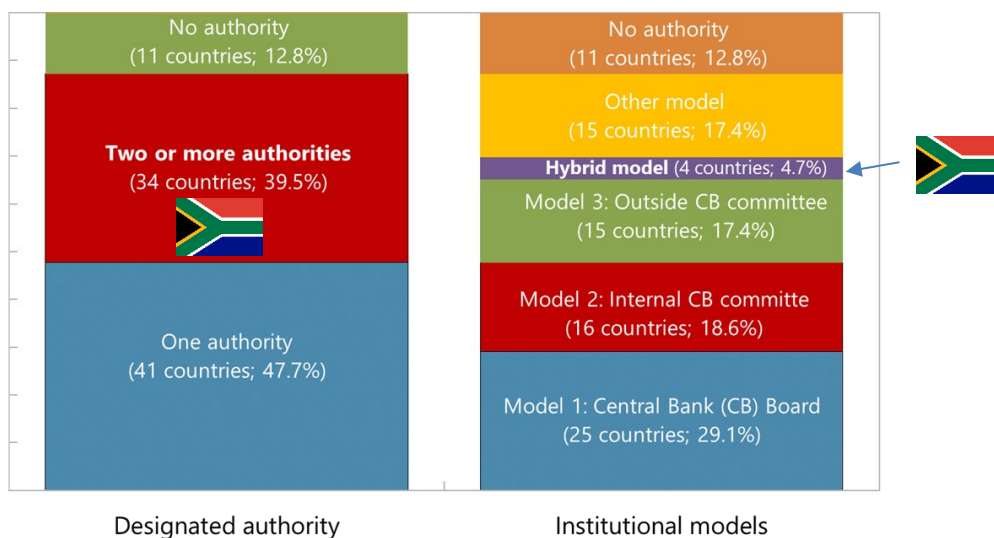

¹ Models #1-#3 are labeled in accordance with [the 2014 IMF SGN](#).

Sources: IMF Macroprudential Policy Survey, IMF staff calculations and illustrations.

13. However, this is problematic in practice, may foster the inaction bias, and it is telling that the COVID-19 pandemic was not labeled as a systemic event. This reflects the stigma associated with such a declaration and the risk of further fueling financial dislocations by facilitating further concerns about the severity of the event. As a result, policy makers may be reluctant to make such a declaration, or at least from a macroprudential policy perspective, it risks action being taken too late. This institutional feature may also blur the distinction between macroprudential policy and crisis management policies, which may give rise to tensions between the two.

C. Coordination and Cooperation

14. Effective institutional arrangements to ensure close cooperation between regulators serve as important mitigants against the inaction bias and somewhat narrow powers of the SARB. This is reflected by in particular, the strong legal requirements for cooperation, the committee structures that entail overlap in membership (importantly also across to monetary policy), explicit financial stability mandates of institutions, and presence of information sharing mechanisms.

D. Recommendations

15. The SARBs power to put in place macroprudential measures should extend beyond SIFIs if needed, and the need to declare an event as systemic should be reconsidered. As noted above SARB's authority is mostly confined to SIFIs, except when the Governor declared an event as systemic. While SIFIs can on their own pose systemic risks, such risks can also arise without any failure of an individual financial institution where e.g., capital or liquidity stress arise and leads to the disruption of financial services ([IMF-FSB-BIS, 2009](#)). This arrangement also makes the institutional framework vulnerable to leakage, reflecting that financial intermediation may migrate outside of the SIFIs that are subject to macroprudential restrictions, in particular if regulatory constraints are tightened further. As discussed below, the macroprudential policy toolkit is narrow in South Africa compared to peers and bank centric. If the toolkit were to broaden, or become more tightly calibrated, the risk of domestic and cross-border leakage would likely rise, in particular if credit developments would start to improve considerably. Furthermore, the need to declare an event as systemic entails risk of unintended side-effects, including fostering too late policy actions, in particular in cases where policy actions need to go beyond the SIFIs to be effective. Hence, this could be reconsidered, in particular when other amendments to the FSR Act would be planned as well.



16. The FSC could consider publishing a short record of its meeting, in particular when the Financial Stability Review is not being published, to further enhance transparency. This would provide market participants and the general public with more frequent assessment of systemic risk and how the FSC sees it evolving between meetings. Examples of such arrangements include Iceland and Romania. This could help overcoming the inaction bias as well as foster a broader understanding of macroprudential policy. Providing at least the FSOC with an opportunity to comment on the meeting records in a similar manner as they do with the Financial Stability Review could be continued.

SYSTEMIC RISK MONITORING

17. Macroprudential policy needs to rely on adequate monitoring of systemic vulnerabilities to be effective in mitigating risks. This may entail so-called ‘guided discretion’ where key indicators are used to generate signals of when policy action might be needed, but the ultimate decision is based on judgement that takes into account all relevant information. Such judgment requires access to data, as well as the analytical capacity to assess systemic risks and effectively map risk assessment into policy recommendations and action.

A. Systemic Risk Monitoring Framework

18. SARB’s systemic risk monitoring framework is well advanced and has followed examples set by advanced and EME central banks alike, as well as Fund guidance. SARB utilizes a number of relevant macrofinancial indicators to build a heatmap of different types of risks. It also relies on financial conditions and financial cycle analysis, as well as the growth-at-risk framework. Stress test capacity has been built-up in line with the 2014 FSAP recommendations and include both solvency and liquidity stress tests. Finally, the SARB summarizes its overall assessment in the risk assessment matrix (RAM) and how it has evolved over time in the Financial Stability Review (Figure 2, text figure).

19. However, SARB’s access to micro-level data is limited, providing limitations for assessment of tail risks, as well as to guide the calibration of macroprudential tools.⁴ Systemic vulnerabilities can arise against the backdrop of relatively slow-growing broad credit developments, indeed tail risk play an important role in systemic risk monitoring. Hence, there has been a growing awareness of complementing aggregate (or sectoral) data with micro-level data that allows for looking at the distribution across different types of borrowers. This allows for more timely identification of growing tail risks and to assess the need for policy action in a targeted manner. Access to micro-level data can facilitate the calibration of, in particular, borrower-based, tools ([Nier et al., 2019](#)), assess the effects of a crisis on borrowers ([Olafsson and Vignisdottir, 2012](#)) or assist policy making more broadly ([IFC Bulletin, 2021](#)). Hence, despite the term, access to “micro-level” data is critical from a macroeconomic and financial stability perspective. The SARB is aware of the need to attain micro-level data and work is underway to close this data gap, although it remains uncertain how far these efforts will reach.

B. Recommendations

20. Continue the important work on developing a national central credit registry to facilitate risk analysis and calibration of macroprudential tools. This is a resource-demanding endeavor where different financial regulators need to collaborate and agree on the overall approach and set-up. What is important from the perspective of SARB is to attain timely and reliable micro-level data, preferably not only regarding loans, but also borrower characteristics, including importantly income. The coverage of the loans would need to include unsecured loans as well as mortgages, from both banks and other lenders, for the SARB to be able to effectively monitor risk

⁴ This reflects lack of information powers to collect this type of data and therefore the need to work with the NCR.

and leakages. Whether to include corporate loans is a question of resources and the legal and practical challenges associated with that. Some countries have opted to only gather corporate loan data above a certain threshold.

Figure 2. South Africa: Systemic Risk Monitoring

Macrofinancial indicators are summarized in a heat map ...

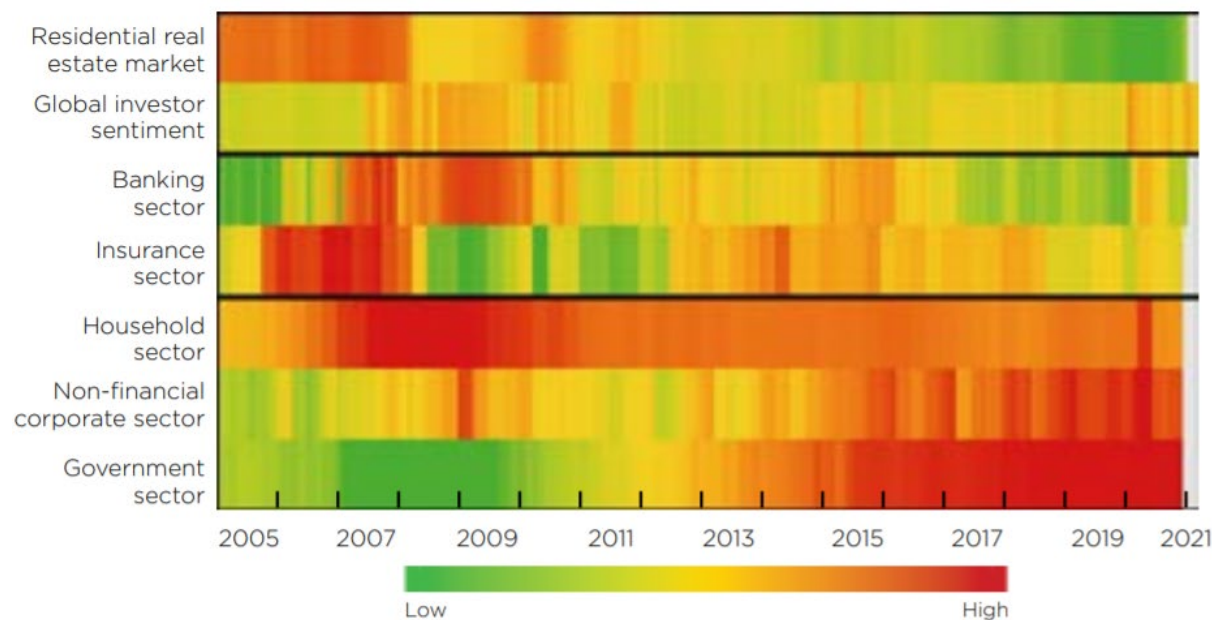

... with SARB's overall risk assessment being summarized in the RAM.

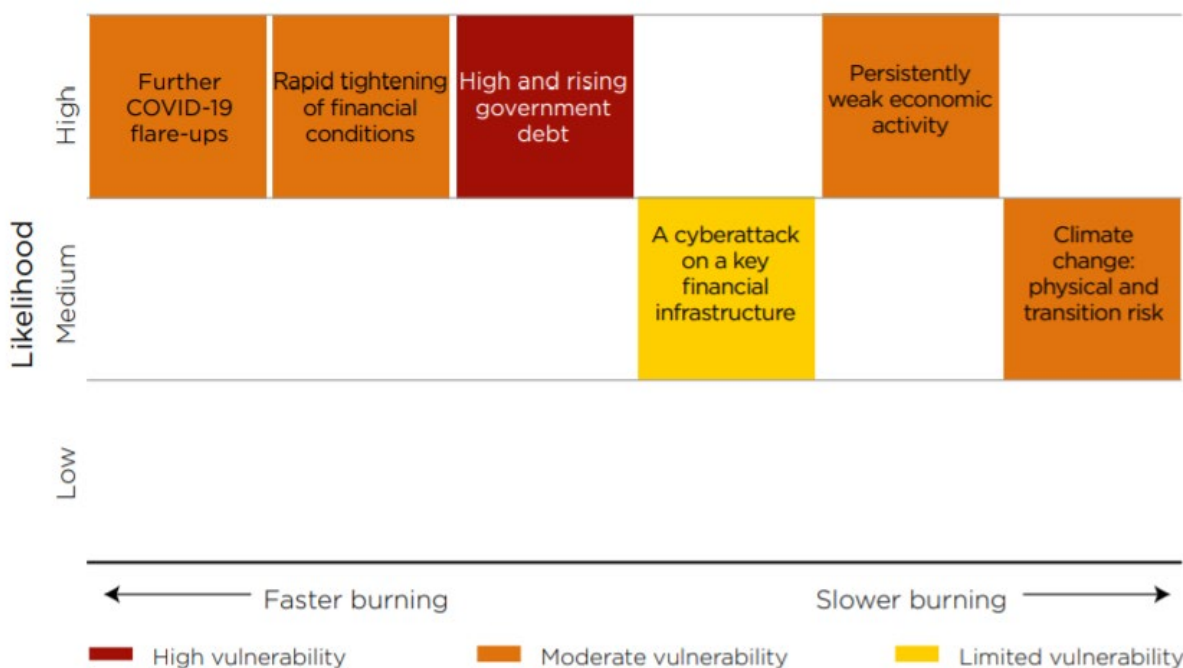

Source: SARB Financial Stability Review 2021:1.

THE MACROPRUDENTIAL TOOLKIT⁵

21. This section assesses the adequacy of the macroprudential toolkit against the backdrop of those financial vulnerabilities, which are identified in the FSAP’s risk analysis.

Effective macroprudential policy making relies on having a diversified portfolio of tools to mitigate systemic vulnerabilities and enhance the resilience of the financial system. Generally, over-reliance on a narrow set of tools risks attaining a less beneficial cost-benefit trade-off and exposing policy makers to more leakages.

22. South Africa stands out as having taken less macroprudential policy actions compared to EME peers, which mostly reflect weaker credit and economic growth developments.

Based on the Fund’s iMaPP database, South Africa began relatively late in taking policy actions compared to peers who began shortly after the global financial crisis (GFC). More or less, the policy action taken in South Africa reflects the introduction of Basel III measures, which were gradually phased-in, while weak overall credit developments and subsequently GDP growth declines made measures to address credit and asset price bubbles less urgent. Indeed, excessive credit developments were rather a feature in the pre-GFC period in South Africa.

23. The reliance on first and foremost Basel III measures has left South Africa with a macroprudential toolkit, which is narrower and to a larger extent bank centric compared to peers (Figure 3). The main broad-based capital tools in place are the CCyB—which as a result of the weak broad credit developments has been kept at zero—, a 2.5 percent capital conservation buffer (CCB), a 4 percent leverage ratio (compared to 3 percent norm in Basel III), and 1 percent systemic Pillar II capital add-on (set by the PA). The last one was introduced to reflect that South Africa is a small open economy exposed to external shocks and the capital add-on is meant to build additional resilience in the banking sector. This add-on was temporarily relaxed in the pandemic. Domestic systematically important banks (DSIBs)—currently all SIFIs designated by the SARB are classified as D-SIBs by the PA—face capital surcharge of 0.5-2.5 percent (set by the PA), with the top bucket currently being empty. On the liquidity side, South Africa has the liquidity coverage ratio (LCR), a liquid asset ratio, and the net stable funding ratio (NSFR).⁶ Hence, there are, no borrower-based tools, no sectoral capital buffers or RWs, and limited scope of macroprudential measures on non-bank financial institutions (NBFIs).

24. A narrow toolkit poses risk of leakages as the dynamic financial system evolves, in part responding to financial regulations changes.

While the low growth environment may slow down such changes, a transformation of the financial system toward becoming more market-based and where credit extension moves to a greater extent outside of the SIFI banks, cannot be ruled out. In addition to domestic leakages, cross-border leakages can also arise, in particular as the country is continuing liberalizing its capital account. The SARB has been aware of this and the FSC has been

⁵ An overview of existing macroprudential policy measures is provided in Annex I.

⁶ In addition, there is a limit on banks’ net open position, as well as limits on external assets of banks, pension funds and asset management funds as a share of their total assets. The external asset limits are capital flow management measures (CFMs) under the IMF Institutional View, as they are residency-based. See a full list of tools in Annex I.

working on broadening the macroprudential toolkit, beginning before the pandemic shock, and includes considering borrower-based tools. A special working group was set up that reports to the FSC on progress in developing a wider range of macroprudential tools, but it has been inactive due to the pandemic and its functioning, objectives, and membership of the group are currently under review. The SARB has also taken part in the work of the Financial Stability Board on market-based financing, which has been accelerated and broadened after the pandemic-related market turmoil and includes both domestic and cross-border aspects. SARB should carefully monitor this work and any guidance that will emerge. International coordination remains crucial in these efforts given the ease of NBF activity to move across borders in response to any country-specific restrictions.

Figure 3. South Africa: Macroprudential Policy Actions, Credit Developments, and Tools¹

South Africa lacks behind its peers with regard to taking macroprudential policy actions....

Use of Macroprudential Tools in 17 EMs 2008-2018

(Cumulative Net Number of Tightening Actions)

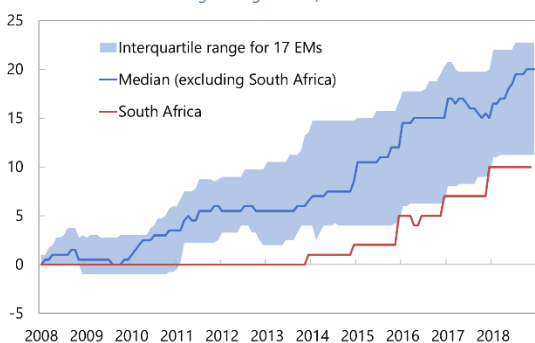

... which mostly reflects weaker broad credit developments.

Credit-to-GDP Gaps in 13 EMs 2008-2018

(Percentage Points of GDP)

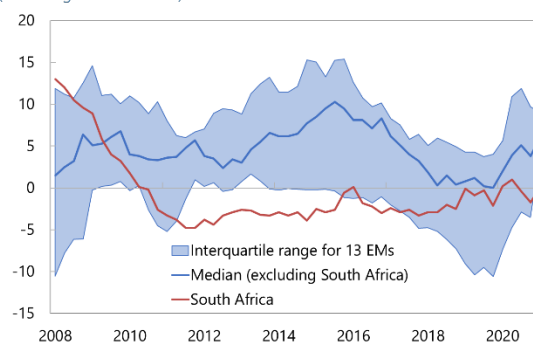

The current framework relies mainly on Basel III-based capital and liquidity tools...

South Africa: Use of Macroprudential Tools 2014-2021

(Cumulative Net Number of Tightening Macroprudential Policy Actions by Type)

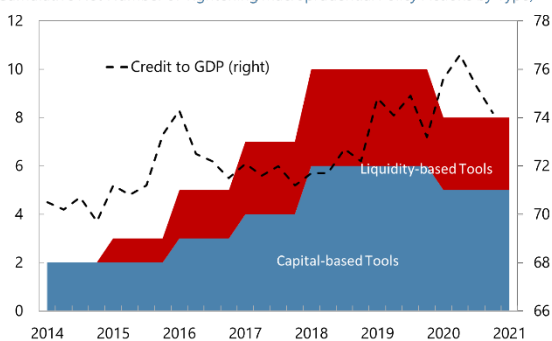

... resulting in South Africa having a narrower and mainly bank-based macroprudential toolkit compared to peers.

Policy toolkit in South Africa and 17 EMEs

(Number of tools by type)

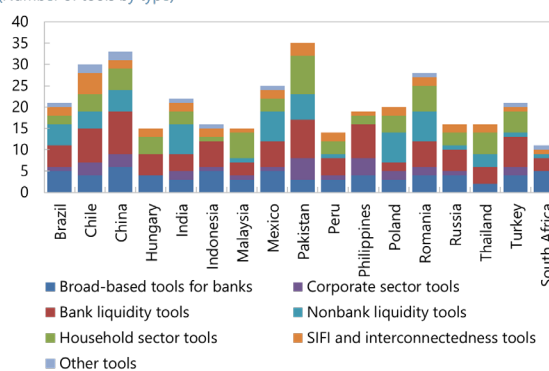

¹ Credit data is not available for all 17 peer countries.

Sources: Bank for International Settlements, IMF iMaPPdatabase, IMF Macroprudential Policy Survey, staff calculations.

25. The FSAP’s risk analysis emphasizes risk stemming from the sovereign-financial nexus, fragilities in the nonfinancial private sector, and banks’ reliance on wholesale funding.⁷ As discussed in the Financial Sector Stability Assessment report, these are some of the key systemic risks identified in the FSAP. The macroprudential toolkit addresses some of these vulnerabilities, in part by providing broad-based capital and liquidity buffers that can be drawn down during stress. However, as noted in context of the pandemic, banks appear somewhat reluctant to make use of buffers as was widely experienced in the crisis but that does not ensure they would be better off without having them available.

26. Some of these vulnerabilities are not targeted specifically in the toolkit as gaps are present with regard to the sovereign-financial nexus and borrower-based tools. Gaps in addressing the sovereign-financial nexus are common across countries, while borrower-based tools remain among the mostly widely used tools. The remainder of this section will focus on these tools, as the bank-based broad macroprudential tools, both with regard to capital and liquidity, are already in place and the authorities are actively taking part in the development of tools for market-based activity at the international level.

A. Measures to Address the Sovereign-Financial Nexus

27. The sovereign-financial nexus has emerged as a challenge for financial stability in a number of countries, in particular as a result of financial distress and crises where financial institutions may need to step in to provide funding to the sovereign as other sources—domestic and foreign—dry up and/or as domestic private credit risk increases and attaining sovereign exposure becomes more attractive. As a result, distortions arise where private credit is crowded-out and systemic risk may materialize and work through various macrofinancial linkages and feedbacks that have been recognized in the literature ([IMF, 2018](#)).

28. Addressing the sovereign-financial nexus has proven difficult for a number of reasons, as also evidenced by the inability to reach international consensus ([Basel Committee on Banking Supervision \(BCBS\), 2017](#)). From a macroprudential perspective, this reflects trade-offs and thereby potential clashes with other policies, risks of unintended side-effects, and the lack of experience and agreement with utilizing macroprudential tools to address this risk. Hence, proceeding with a high degree of caution and aiming to achieve a broad domestic policy agreement is desirable to attain a desirable trade-off.

29. In South Africa, exposure of banks and the financial sector more broadly towards the sovereign is increasing, while still not being excessive in international comparison.⁸ In addition, there are important mitigants in place, such as a relatively benign currency and maturity profile of government debt. However, there are also potential amplifiers. In particular, the fiscal and growth outlook risk aggravating the nexus going forward, as well as if nonresidents’ holdings would continue to decline, which cannot be excluded given the credit rating developments and the

⁷ See further information in the Financial System Stability Assessment and the Technical Note on the Risk Analysis.

⁸ See Figure 4 in the Financial System Stability Assessment.

potential of a tightening of global financial conditions. Indeed, the risk stemming from the nexus is reflected in the FSAP's solvency stress test, which reveals sizable losses resulting from sovereign exposures in the adverse scenario over the 3-year horizon. SARB has also flagged this as a key systemic risk (Figure 2 above, [SARB Financial Stability Review 2021:1](#) and [Smith et al., 2020](#)).

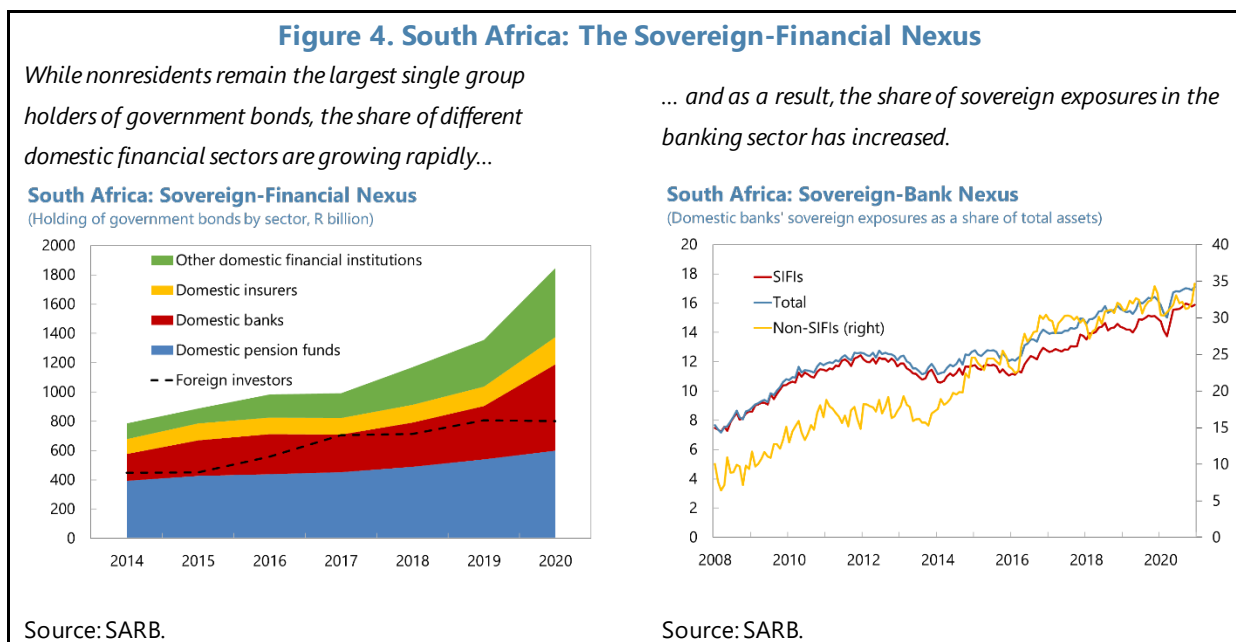

30. Fiscal consolidation is likely to have to be key in reducing the sovereign risk in the financial sector, but prudential policies can play an important complementary role. Ensuring debt sustainability and strengthening the growth outlook (which is discussed in the Article IV consultations) could reduce the risk associated with the sovereign-financial nexus and support a wider diversification toward the private sector on financial institutions' balance sheet. An important question to ask is how prudential policies could complement that, being mindful that there is an underlying distortion arising from how sovereign exposures are generally treated under the Basel III framework.

31. Any prudential measure that could be considered to address the nexus should be mindful of other prudential requirements and the broader need for financial institutions to hold government bonds. In particular, the need to hold high quality liquid assets (HQLAs) to fulfill the LCR requirements—and some voluntary buffer on top of that—and to fulfill banks role in the government bond market. Similarly, many NBFIs also need to hold government bonds, at least voluntarily, for similar liquidity purposes. This will need to be considered in the design of any prudential measure to address the nexus.

32. Similarly, any measure would need to be mindful of the importance of safeguarding the smooth function of the government bond market and banks' liquidity and profitability. Potential tensions between prudential policies to address the nexus and fiscal policies' objectives with regard to funding costs and smooth functioning of government bond markets are key to address in the design of any prudential measure aimed at the nexus. Similarly, the effects on

financial institutions' liquidity and profitability would need to be considered carefully, as these are the first line of buffers when shocks materialize—even those stemming from sovereign risk.

33. Hence, prudential measures should aim at (i) ensuring resilience through increased loss absorbing capacity and (ii) providing disincentives against excessive concentration of sovereign risk, while at the same time (iii) avoiding unintended side-effects. As discussed above, these unintended side-effects could take the form of an excessive reduction of liquidity, bond market pressures with resulting effects on government financing, or other unwarranted macro-financial dynamics (see paragraph 35 below). The discussion below will focus on the sovereign-bank nexus, as discussed in paragraph 24, measures on NBFIs are likely to reflect international agreements on strengthening their prudential regulations.

34. Various measures can be considered, but regardless, they would need to be phased-in, be carefully calibrated, and clearly communicated, for them to be likely to achieve their objectives:

- **Higher risk weights:** Given that a key source of distortions emanates from the preferential risk-weight treatment of sovereign exposures—in line with the national discretion embedded in the Basel framework—increasing RWA arises as a natural response. Importantly, IRB banks have already endogenously increased RWA on their sovereign holdings and thereby hold more capital against them. Similarly, the authorities could consider introducing positive RWA on banks that apply the standardized approach and thereby combine a two-fold solution. However, the potential for procyclical dynamics would need to be considered ([Véron, 2017](#)).
- **Capital surcharges:** Another option would be to apply Pillar 1 or 2 capital surcharges, which can be calibrated in a manner that is commensurate to the assessed risk. Importantly, they should allow for increased resilience and disincentives to building excessive concentration, while limiting risk of unintended side-effects. For instance, by applying positive surcharges only above a certain thresholds (to account for holdings of sovereign bonds to meet liquidity requirements, etc. as listed above), and then rise only gradually as financial institutions' exposures increase as a share of assets (see an example of such a calibration in [2018 Romania FSSA](#)).⁹ Potentially, capital surcharges—if they are being used as usable buffers—could be relaxed if sovereign risk would materialize, providing additional resilience. However, any such relaxation would need to be implemented carefully and judgement applied to the cost-benefit trade-offs (see IMF, 2014), including how useable such released buffers would be in practice.
- **Concentration limits:** A third option is to use a quantitative measure, instead of price-based ones, in the form of concentration limits. Such measures would reduce concentration, but unintended side-effects in the form of 'cliff effects' may materialize when banks would come close to the limits and might need to resort to fire sales of bonds with detrimental effects.

⁹ Other examples of FSAP recommendations to deal with the sovereign-financial nexus include [Italy](#) and [Poland](#).

35. Quantitative assessments could guide the calibration and help with communication of prudential measures to address the sovereign-financial nexus. Stress tests can help with assessing the level of resilience which any measure should aim to provide, for instance, through higher RWs or capital surcharges. Not necessarily such that the measure should provide ‘insurance’ against the full set of losses in an adverse scenario, but to pass judgement on the desired level of resilience against these potential losses. Furthermore, quantitative impact assessments could look into the potential effects of any measure taken on at least four areas: (i) bank funding costs; (ii) bond yields; (iii) bank profitability; and (iv) bank liquidity position. For an example of such an analysis, see the [2018 Romania FSSA](#).

36. Another challenge associated with introducing prudential measures to address the sovereign-financial nexus, is on timing. SARB already has a framework in place to guide the introduction of macroprudential tools, and how to weigh the cost-benefit trade-offs—including assessing the cost of inaction—which could be useful in this regard.

37. It is advisable to start the implementation before there is a significant further build-up of this risk in financial institutions’ balance sheets. Also, taking into account the normalization of pandemic-related relaxation of capital requirements and the broader economic context. A reasonable transition period will be needed to allow financial institutions time to adjust their balance sheets; but a near-term announcement of envisaged measures, with the applicable transition period, can help condition behavior and thus smooth the adjustment process.

38. Communication is going to be key to smooth implementation of any new measures. The SARB has already taken a crucial step in this regard by providing a thorough analysis of the risks associated with the nexus. Next step is to set out the objectives, weigh the different policy options against those objectives, and perform a quantitative analysis to guide the calibration. Once a suggested calibration is in place, the various platforms in the committee structures can be utilized to build consensus, followed by a more-wider communication and a phase-in period.

B. Borrower-Based Tools

39. Borrower-based tools are among the most widely used macroprudential policy tools around the world ([Alam et al., 2019](#)), but they have so far not been implemented in South Africa. This is somewhat understandable given the broader macro-financial context in the post-GFC period, as well as due to the time it often takes to be able to use such tools in an effective manner given that preparations have been underway by the SARB.

40. Going forward, such tools might be needed to complement the mostly capital tools that are in place. Experience shows that capital-based tools, while providing important resilience against shocks, are less effective than borrower-based tools in reducing credit growth and feedbacks between asset prices and credit. Borrower-based tools also have the benefit of being targeted and can thereby complement broader capital tools to achieve an improved cost-benefit trade-offs if broader credit developments are weak but the are pockets of vulnerabilities in certain sectors.

41. The SARB is well-aware of this, and as noted above, work has been underway to broaden the toolkit to include borrower-based tools, such as caps on loan-to-value (LTV), debt service to income (DSTI) or debt/loan to income (DTI/LTI). Also taking into account the resilience enhancement of borrowers embedded in the NCA legislation.

42. Closing data gaps is an important element to foster that broadening, including preferably through a credit registry, and making sure the legal framework allows for the use of these tools. The importance of closing data gaps was discussed above. In many instances the legal basis for allowing the use of these tools has to be strengthened. The FSR Act provides for the use of sectoral tools, but it is not clear whether that applies only to sectoral capital (and liquidity) tools or also borrower-based tools. Most likely, a 2nd tier legislation to the FSR Act could establish a framework for the application of borrower based macroprudential tools.

43. As these tools can be quite effective, it is important to consider avoiding excessive costs, and for South Africa, not to undermine efforts to enhance financial inclusion. These cost include (healthy) borrowing being discouraged (potentially slowing down the post-COVID recovery), excessively undermining consumption growth and thereby economic growth by requiring too much saving, and undermining financial inclusion. Ultimately, if these costs become excessive, macroprudential policy could risk losing its autonomy. Various design features can be considered to achieve a more beneficial cost-benefit trade-off when using borrower-based tools. In particular,

- More generous LTV caps for first time buyers;
- Allow for “speed limits” where banks can deviate from the requirements for a certain share of new loans;
- Consider ways to allow banks to perform their own income assessments of borrowers to take all income into account which appears to be addressed in the NCA;
- Consider issuing guidelines on LTV and DSTI ahead of binding rules to be able to observe their impact and guide the calibration;
- Aim to start the caps at a relatively neutral rates and gradually tighten.

44. To be effective, it is generally advisable to rely on a portfolio of borrower-based tools rather than any one single tool. In particular, if sectoral credit growth is strong an income-related measure (such as a DSTI or LTI) is likely to be needed as those are less affected by interactions between asset prices and credit as the LTV.

C. Recommendations

45. Consider carefully calibrated prudential measures to address the sovereign-financial nexus. The measure(s) should have clear objectives (as suggested above), be calibrated and implemented manner to achieve those objectives, and be clearly communicated to foster understanding of the need for policy action and diminish concerns of unintended side-effects.

46. Continue preparations to use borrower-based tools and consider design features that could allow for a more beneficial cost-benefit tradeoffs, taking South African country-specific circumstances into account.

Annex I. Macroprudential Policy Measures in Place

Prudential Policy Measures ¹		
Measure	Introduced	Last adjusted
Countercyclical capital buffer 0 percent	Framework in place since January 1, 2016, but announced since April 2013	Kept at zero throughout
Capital conservation buffer 2.5 percent	Fully implemented since January 1, 2019, but phased-in starting January 1, 2016, as announced in April 2013	Banks were encouraged to make use of the buffer from April 6, 2020 as part of the pandemic policy response
Leverage ratio 4 percent	Fully implemented from January 1, 2018 as announced in May 2016	Has not been adjusted since January 1, 2018
Forward-looking loan provisioning (IFSR 9)	From financial years ending after January 1, 2018	Clarified in March and May 2020 as part of the pandemic response
Pillar 2A capital requirements 1 percent (systemic add-on)		Relaxed April 6, 2020 as part of the pandemic response, but to be reinstated from January 1, 2022
Liquidity coverage ratio 100 percent	Phased in from January 1, 2015 to become fully implemented by January 1, 2019 as announced in December 2012	Reduced to 80 percent from April 1, 2020 as part of the policy response to the pandemic
Liquid asset ratio 5% of their adjustable assets	In place since the late 1990s	
Net stable funding ratio 100 percent	From January 1, 2018 as announced in December 2012	Has not been adjusted
Capital surcharge on domestically systematically important institutions 0.5-2.5 percent	Phased-in January 1, 2016 to January 1, 2019	Has not been adjusted

¹ Some of these measures can be seen as macro-, micro-prudential, or both.