

INTERNATIONAL MONETARY FUND
GEM: A New International Macroeconomic Model

Prepared by the Research Department

Approved by Raghuram Rajan

January 2004

Contents	Page
I. Introduction	3
II. Philosophy and Approach	4
III. How Has GEM Been Used?	17
IV. Current Development Work	30
V. The Road Ahead.....	35
Issues for Discussion.....	37
References.....	38
 Boxes	
II-1. Estimating Parameter Values.....	12
III-1. GEM Simulations of the Benefits of Greater Euro Area Competition.....	20
III-2. Using GEM to Analyze Monetary Policy Rules	25
 Figures	
II-1. Stylized View of Model Development	5
II-2. Simple GEM Structure.....	9
II-3. More Complicated GEM Structure.....	10
II-4. Dynamic Responses of GEM Compared to Large Forecasting Models	13
II-5. Dynamic Responses of GEM Compared to a VAR.....	14
III-1. Dynamic Effects of More Competition-friendly Policies in the Euro Area	23
III-2. Taylor Tradeoff in Monetary Policy Analysis.....	24
III-3. GEM: Impact of a Permanent 20 percent Increase in Oil Prices After One Year.....	29
III-4. GEM: Impact of a Permanent and Temporary 20 Percent Oil Price Hike After One Year.....	31
IV-1. Structural Fiscal Balances in the Major Economic Regions	32
IV-2. The Sum of International Assets and Liabilities in the G7	33

IV-3. Capital Constraints for Emerging Markets..... 35

Tables

II-1. Stylized View of the Strengths and Weaknesses of Successive Generations
of Macro Models..... 6

III-1. GEM Estimates of the Long-Run Effects of More Competition-friendly
Policies in the Euro Area 22

III-2. MULTIMOD: Impact of a Permanent \$5 a Barrel Increase in Oil Prices
After One Year..... 28

I. INTRODUCTION

1. Over the last two years, the staff has been developing a new multi-country macroeconomic model called the Global Economy Model (GEM).¹ An obvious question is why such a model is needed, given that the Fund's existing model, MULTIMOD, also focuses on interdependence across countries. This paper answers this question by explaining how GEM differs from its predecessor, and outlining how these new features can improve the Fund's policy analysis. The paper is aimed at the general audience and avoids technical detail. It comprises five sections, this introduction, a second section outlining the motivation, structure, strengths, and limitations of the model, and a third comprising a more detailed discussion of three simulation exercises that have been completed. Section four looks at areas in which development of the model is currently underway, while the final section provides a more general discussion of GEM's future path. Some issues for discussion conclude the paper.

2. To provide a foretaste, GEM is an early example of a large international macroeconomic model built using recent economic research based on an explicit microeconomic framework in which consumers maximize utility and producers do the same with profits. In particular, the integration of domestic supply, demand, trade, and international asset markets in a single theoretical structure allows transmission mechanisms to be fully articulated, providing a range of new insights not obtainable from earlier models more loosely linked to theory. Being on the forefront of this work has many advantages including ensuring that Fund analysis incorporates recent theoretical advances in international macroeconomics and finance. There is a parallel with the introduction of rational expectations into policy models in the 1980s (of which MULTIMOD was a pioneering effort for multi-country work) whose more sophisticated dynamic responses to aggregate demand disturbances also led to a range of new insights. Indeed, the Fund is again on the cutting edge of developing international policy models with GEM. While still very much a project in development, GEM is already the model of choice for most policy simulations although MULTIMOD remains useful for some types of analysis.

3. A range of GEM simulations has already been used in Fund work to assess issues such as the domestic and international consequences of policies to increase competition in markets, the impact of oil price hikes, the effects of exchange rate volatility across industrial countries on emerging markets, and appropriate monetary policy rules for emerging market countries. To take a specific example, GEM was used to identify the benefits of greater competition in the euro area in a manner that was not possible in earlier models. This was

¹ The GEM project was initiated by Kenneth Rogoff when he was Director of the Research Department. GEM has been very much a team effort. The initial development of the model mainly involved Douglas Laxton and Paolo Pesenti (who came on a 6-month secondment from the New York Federal Reserve Board). Subsequent development has also involved Benjamin Hunt, Philippe Karam, and Alessandro Rebucci. Michel Juillard and Susanna Mursula have been critical since the project's inception in helping to develop the toolbox to support the development and use of the model.

achievable because the level of competition across firms is explicitly modeled in GEM, so that the impact of changing it can be analyzed directly. In addition, the simulation indicates that greater competition in labor and product markets also fosters greater wage and price flexibility, an intuitive result that again reflected the microeconomic foundations of the model, this time with respect to the setting of prices and wages.

II. PHILOSOPHY AND APPROACH

Why a New Model?

4. The development and rationale for GEM can be best explained through a brief description of the role of large macroeconomic policy models. Academic work in macroeconomics tends to focus on specific issues, such as the consumption function or a new theoretical insight. Large macroeconomic policy models, on the other hand, are used to quantify the impact of a range of issues within a unified structure, most notably counter-cyclical macroeconomic policies. A stylized way of thinking about the interaction between academic work and large policy models is provided in Figure II-1. A new theoretical insight (such as rational expectations) with strong policy implications is developed in academia in response to evolving policy challenges and the limitations of existing models. Once these ideas have been distilled to the point where they are able to fit the data reasonably, they form the basis for large policy models, starting with single-country versions and then extending to a multi-country setting. Subsequently, the academic and policy communities refine these ideas and the paradigm becomes increasingly dominant. At some point, a new insight emerges and the leading edge of academic work switches to this new paradigm. However, large policy models do not follow because the ideas are not yet able to provide the needed quantitative insights, and academic interest in large macroeconomic models wanes. In short, the “production cycle” of policy models tends to lag that of their academic brethren, given the greater need for policy models to fit the stylized facts of the cycle.

5. One such major overhaul occurred with the adoption of rational expectations (Table II-1 summarizes successive generations of policy models). In the 1960s and 1970s large policy models using adaptive expectations and a Keynesian aggregate demand framework quantified the impact of macroeconomic policies. However, in the wake of the great inflation of the 1970s, the implication that output could be raised permanently by injecting aggregate demand through monetary and fiscal policy was recognized as a flaw. Rational expectations fixed this and provided a new range of insights, such as the importance of rules in macroeconomic analysis (Taylor, 1993), exchange rate overshooting (Dornbusch, 1976), and the “random-walk” model of consumption (Hall, 1978). Such models were gradually developed to the point where they could be used in policy circles. Indeed, MULTIMOD, created in the late 1980s, was an early example of a large international version of such a model (see Masson, Symansky, and Meredith, 1990, for a description).

6. These rational expectations models, however, were susceptible to the “Lucas critique.” This was that policy analysis using reduced-form equations that fit the data but were loosely tied to theory—such as those used in large macroeconomic policy models—was fraught with danger, as such models could not adequately account for resulting shifts in behavior (Lucas, 1976). The focus in much of academia in the 1980s and early 1990s was on developing rational-expectations models incorporating the explicit microeconomic structure

Figure II-1. Stylized View of Model Development

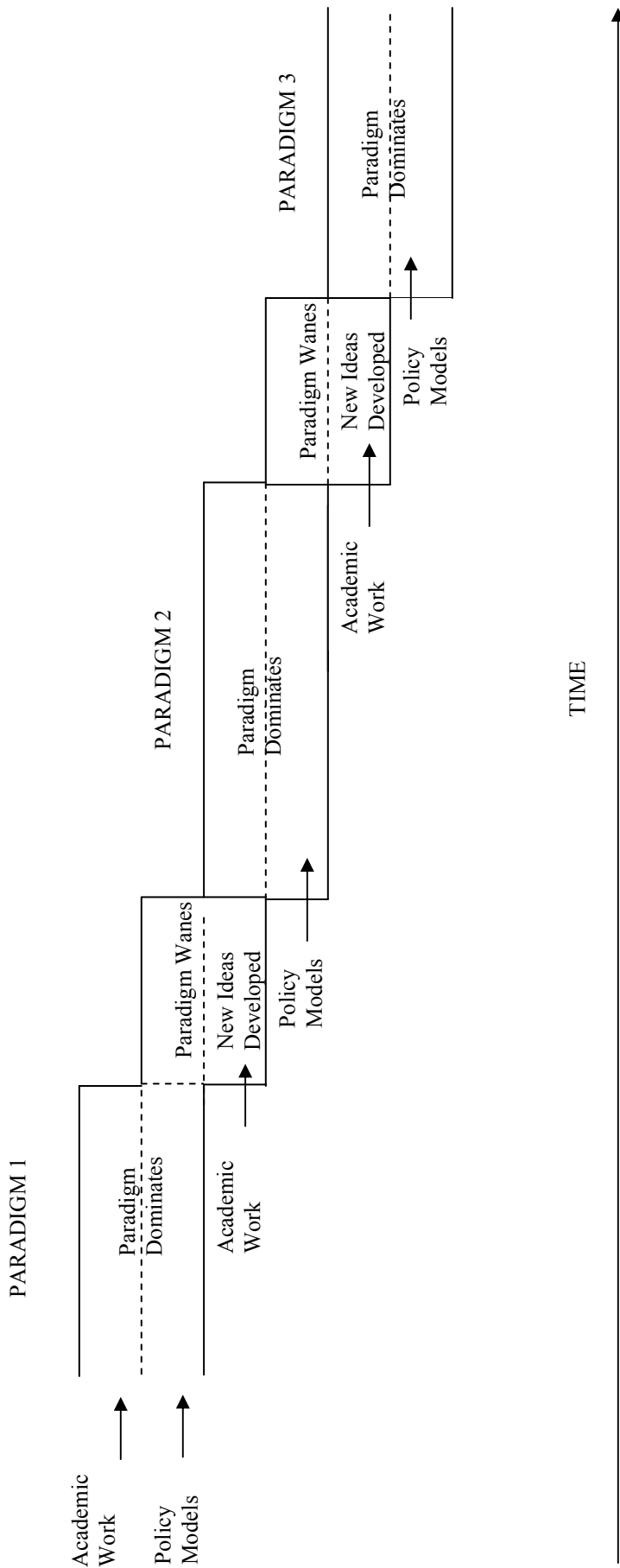

advocated by Lucas. Initially this took the form of “real-business-cycle” models in which prices were assumed to be fully flexible (see Kydland and Prescott, 1982, for a closed economy version and Mendoza, 1991, written in the Research department of the Fund for an open economy one). However, the assumption of flexible prices largely obviated the impact of macroeconomic policies on real activity, making these models of little value in analyzing such policies. Consequently, large policy models generally remained in the reduced-form Keynesian framework, although with an increased focus on adding supply-side linkages.

Table II-1. Stylized View of the Strengths and Weaknesses of Successive Generations of Macroeconomic Models

Model Type	Keynesian Adaptive Expectations	Keynesian Rational Expectations	Real Business Cycle	Stochastic Dynamic General Equilibrium
Strengths	Allowed researchers to assess the impact of policies and other cyclical shocks in a unified manner.	Generated more realistic dynamic responses to cyclical disturbances.	Strong theoretical foundations improved supply side and allowed direct calculation of welfare.	Integrates aggregate supply and demand responses through microeconomic theory.
Weaknesses	Adaptive expectations allowed policy makers to consistently mislead others, creating a bias toward expansionary macroeconomic policies.	Absence of strong theoretical foundations made it difficult to assess effects of policies on aggregate supply.	Assumption of flexible prices left little room for analysis of macroeconomic policies.	Models are in early stages of development and are difficult to build and run.
Major Fund Contributions to International Analysis	Mundell-Flemming Model, Mundell (1963) and Flemming (1962)	MULTIMOD	Mendoza (1991)	GEM

7. Over time, it became increasingly clear that the short-term dynamics of real-business-cycle models could be improved by introducing some form of nominal inertia. Theoretical developments in the microeconomics of wage and price setting with imperfect competition led to single-country monetary models that combined the explicit microeconomic foundations typical in real business cycle models with price stickiness (Christiano, Eichenbaum, and Evans, 2001). The leap to multi-country models of this type was accomplished in the mid-1990s (Obstfeld and Rogoff, 1995). The new models merged the microeconomic foundations (of the type advocated by Lucas) with sticky prices, combining production, consumption, nominal rigidities, trade, and international financial markets in a coherent theoretical structure. Work on such models has exploded in recent years (Lane, 2000, provides a survey).

8. This deep paradigm shift is transforming the study of international finance and international macroeconomics, reevaluating the Mundell-Flemming analysis developed at the

Fund in the early 1960s, in the same way that the traditional IS/LM/Phillips curve analysis was recast by recent monetary models (see Obstfeld, 2001). Major insights from these models include that macroeconomic policies, such as the exchange rate regime, can have long-term effects on the level of consumption, labor effort, and the capital stock, in contrast to earlier views generally held in the profession. In addition, policies can be analyzed in terms of their impact on economic welfare of consumers—which includes, for example, the disutility of working harder and having less leisure—rather than their effect on less accurate proxies for welfare such as output and inflation. This has reignited interest in the impact of alternative exchange rate regimes, the benefits from international macroeconomic cooperation, and the role of asset markets in the international business cycle.

Structure of GEM

9. GEM is a large-scale version of such a micro-founded open economy model. It integrates and builds upon the results in the existing literature—mostly devoted to exploring small and relatively tractable apparatuses—to create a unifying framework for the analysis of international interdependencies. GEM has a modular structure, allowing the model to treat issues in a flexible manner. In addition to GEM, such models have been developed by the Federal Reserve Board (Erceg, Guerri, and Gust, 2003), and are areas of active research in several other institutions (such as the central banks of Canada, Italy, Finland, Norway, Spain, and the United Kingdom), and are being considered in some emerging markets, such as the central banks in Brazil, Chile, and the Czech Republic. The ECB has developed a single-country model (Smets and Wouters, 2002) and is planning a multi-country extension.

10. The model comprises firms, who produce goods, households, who consume and provide labor and capital to firms, and a government which taxes and spends (Laxton and Pesenti, 2003). The microeconomic structure of GEM uses standard functional forms that allow firms and consumers to be aggregated as if they were a single entity. On the production side, for example, many small firms produce differentiated goods made using identical constant elasticity of substitution (CES) production functions using labor, capital and (in some cases) intermediate goods such as components or commodities. Because the goods are differentiated, firms have market power and restrict output to create excess profits. Capital and intermediate goods can be produced and traded while the labor force in each country is fixed, with workers choosing how much to work versus enjoying leisure. Workers also have market power and hence restrict their labor to raise their real wage. The workers own the firms in their country, and hence receive their revenues (net of investment) in the form of wages and profits. This income is spent on home and foreign goods based on a CES utility function. Given the focus on trade and macroeconomic interdependencies, the fiscal and financial sides of the model are currently relatively simple. The government spends on government consumption funded through lump-sum taxes less transfers, domestic financial sectors are not modeled explicitly, while countries pay (receive) a small premium for international borrowing (lending). These sectors are all areas of active development (see Section IV).

11. To generate realistic dynamics, the model includes judicious use of adjustment costs on real and nominal variables, thereby elongating the responses to shocks and ensuring that consumption and production do not immediately jump to a new long-term equilibrium. On the real side, such costs prolong the adjustment of the capital stock and the level of imports,

while “habit persistence” plays a similar role in elongating the responses of consumption and hours worked. Sticky prices are also modeled using adjustment costs, with the prices of domestic goods and imports, as well as wages, displaying inertia. These costs are modeled parsimoniously with only one or two parameters determining the speed of response, and are fully integrated into the theoretical structure.

12. An innovative feature of GEM compared to most policy models is that it has a flexible structure, so that one can include or exclude features such as nontraded goods, a distribution sector, or trade in commodities or other intermediate goods. In addition, the model can be created with any number of countries, although work to date has involved either two or three countries. Figure II-2 illustrates the simplest possible version of the two-country model, in which labor and capital are combined to produce a single type of tradable good which can be used for consumption or investment. Given the preferences of consumers, firms, and governments, these goods are then distributed across countries.

13. Figure II-3 shows the same two-country model with three major additional features incorporated. The first new feature is that production is split into two stages. In the first stage, labor, capital and (possibly) land are used to create intermediate goods that can be traded, such as oil or components for manufacturing. These intermediate goods are then combined with additional labor and capital at home and abroad to produce final goods. The addition of intermediate goods allows the model to examine issues which are particularly important for developing countries. These include the policy challenges faced by economies that supply either low value-added components (such as textiles) to industrial countries, assemble higher technology components from such countries into final products (for example, assembling computers), or are commodity producers and exporters.

14. Another feature shown in Figure II-3 is that final goods are split into those that can be traded and those that cannot. Differentiating between traded and nontraded goods is central to a number of issues in international macroeconomics. Most notably, rapid productivity increases in traded goods relative to nontraded goods help explain why real exchange rates tend to appreciate in countries that are growing rapidly—generally referred to as the Balassa-Samuelson effect (Balassa, 1964, and Samuelson, 1964). Including nontraded goods is also useful for many industrial country issues, such as the degree to which actual (and anticipated) productivity increases in IT goods help explain the strong appreciation of the U.S. dollar over the late 1990s (see Hunt and Rebucci, 2003, for an analysis of this issue using GEM).

15. Finally, a distribution sector is included. There is strong evidence from microeconomic studies that the same goods are sold at different prices across countries. One way of incorporating this observation is to include a distribution sector in the model (Corsetti and Dedola, 2001). All domestic and foreign goods need to go through this sector before they can be bought. As the distribution sector is assumed to comprise nontraded goods, this means that the final prices of all goods are an amalgam of the cost of producing these goods and domestic distribution costs, so prices of imported tradable goods do not fully reflect changes in the real exchange rate even in the long run.

Figure II-2. Simple GEM Structure

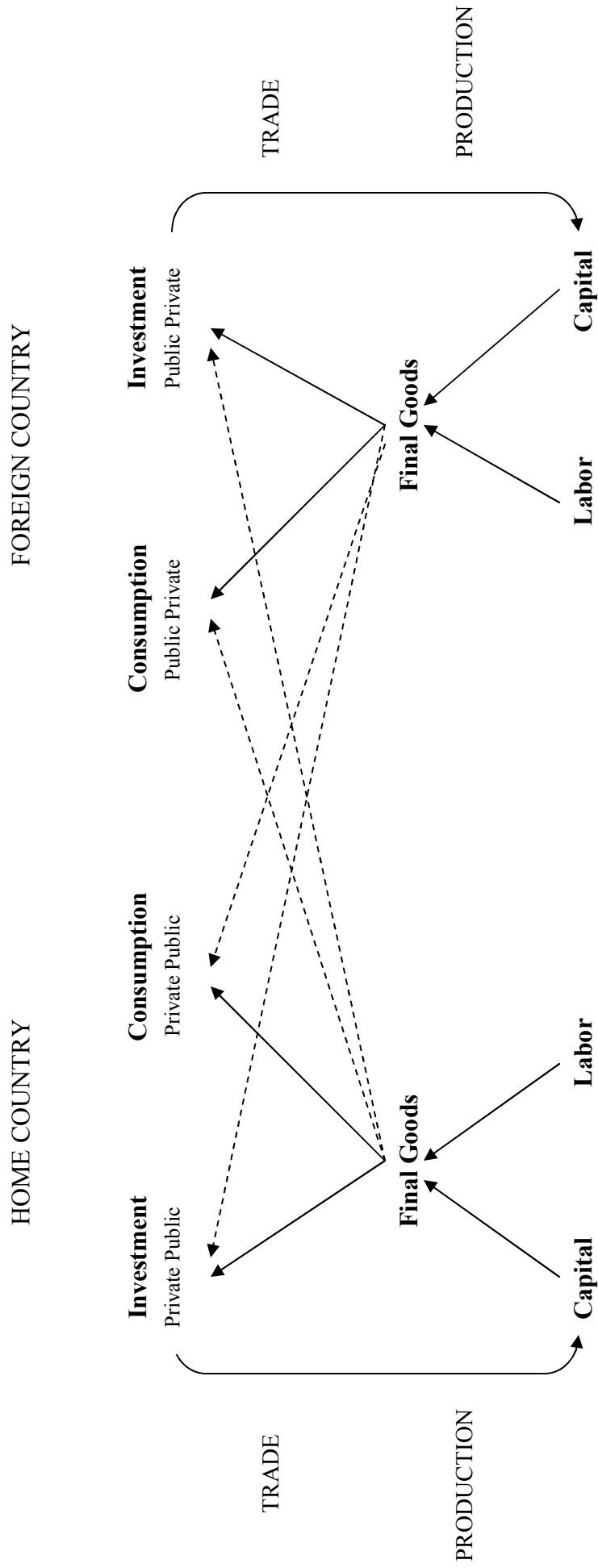
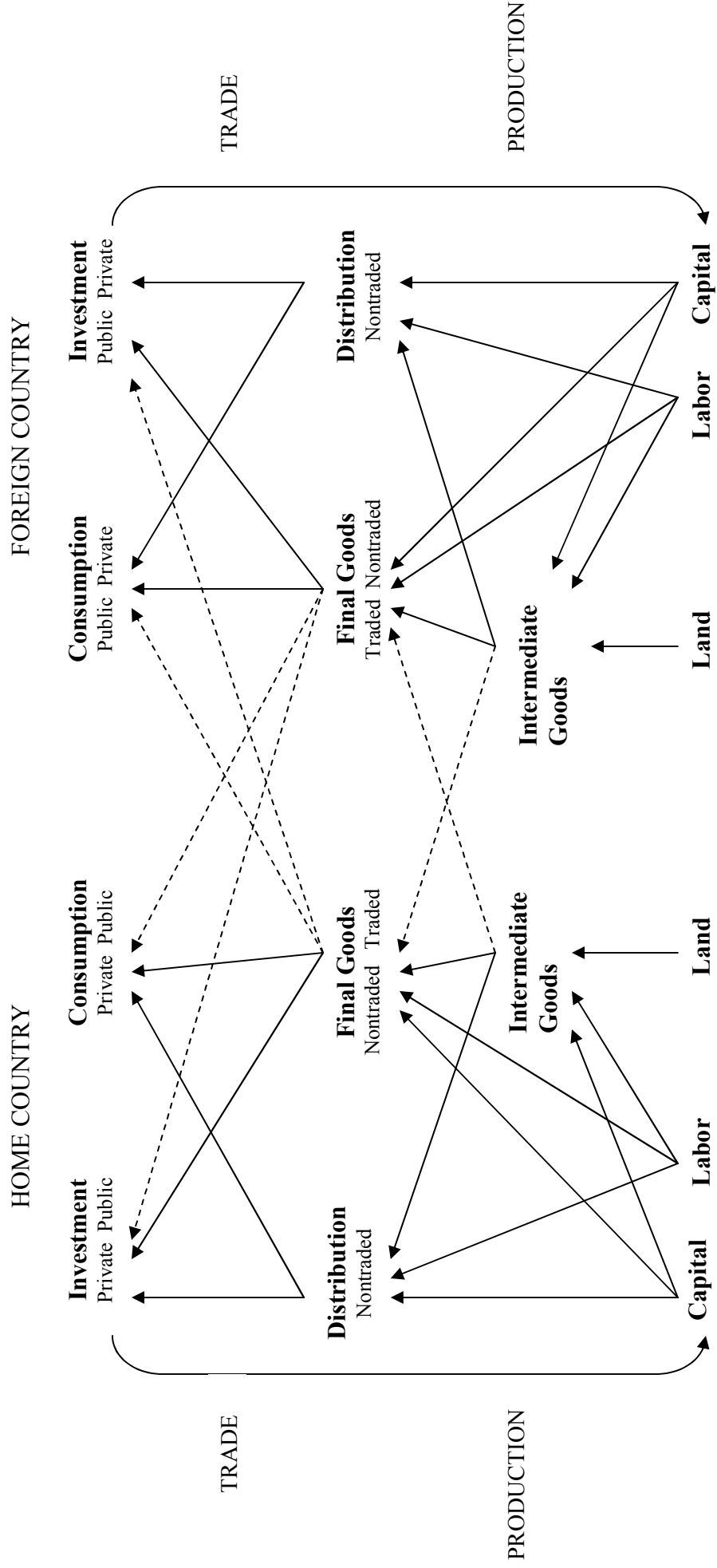

Figure II-3. More Complicated GEM Structure



16. GEM's flexible modular structure provides a number of advantages. Given the size and complexity of the model, it is often useful to ignore factors that are not of central interest to the issue at hand. For example, while one would wish to include commodities when analyzing a major commodities producer, or the impact of oil price shocks, it is essentially a distraction when looking at countries specialized in manufacturing. Similarly, distribution costs matter when pass-through of exchange rates into prices is important, but is an unnecessary complication for many other issues. In addition, the transmission mechanisms become simpler and more transparent in smaller versions of the model, allowing the consequences of the theoretical structure to be more easily ascertained, making the model less of a "black box". Simpler models are also essential for some forms of simulation and estimation that are particularly computer intensive.

17. Once the structure of the model has been determined, the parameters are selected. For most deep parameters that define long-term responses of firms and consumers, such as the responsiveness of hours worked to changes in real wages or the substitutability of different types of goods, estimates from microeconomic studies are used to determine plausible values (Box II-1 discusses issues associated with estimating parameters). Next, more detailed coefficients are selected to mimic key characteristics of the economic environment, such as the relative size of the countries, their levels of trade, and their capital-output ratios. Finally, the coefficients on costs of adjustment and habit persistence are chosen to generate realistic dynamic responses.

18. An important feature of any policy model such as GEM is that it fits the dynamics seen in the data. To this end, the adjustment cost parameters are calibrated to fit existing evidence from policy models and estimated vector autoregressions. Figure II-4 provides a comparison of the responses to a one-year hike in short-term interest rates in the United States and euro area in GEM to those from policy models used in central banks—the ECB's Area-Wide Model (AWM) and the Board of Governor's FRB-US model, respectively. These models were chosen as they are primarily designed to fit the dynamics in the data. An alternative is to compare the model to the responses to an interest rate hike found using an estimated vector autoregression (Figure II-5). In addition to having no imposed theoretical structure, vector autoregressions provide statistical confidence intervals, thereby giving a better sense of the plausibility of the responses produced by GEM.² In both cases, GEM reproduces the typically hump-shaped path of variables, although the GEM responses tend to be somewhat faster particularly for investment, possibly reflecting the absence of lags coming from the time it takes to complete a project once initiated. In short, even with its strong theoretical underpinnings, GEM's structure is rich enough to mimic short-term dynamics.

² That said, not all of the results using VARs are plausible, such as the positive short-term response of prices to a hike in interest rates.

Box II-1. Estimating Parameter Values

The deep parameters in micro-founded models like GEM—such as the degrees to which changes in real wages affect the desire to work, consumption responds to changes in real interest rates, firms can substitute labor and capital in response to changing conditions, and home and foreign goods are substitutes—have generally been calibrated using estimates from microeconomic studies combined with an assessment of the way the model fits the overall properties of the data. Unfortunately, parameterization is time consuming, as it involves experimenting across a wide range of potential values. Ideally, it would be better to simplify this process by estimating the parameters from macroeconomic data.

The major constraint to estimating deep parameters is that their impact on the model's short-term dynamics is often subtle. As the information in the data mainly pertains to these dynamic responses, it is difficult to obtain accurate estimates of crucial elasticities using classical estimation techniques. The standard errors on these coefficients are generally large, and the estimated values often deviate a long way from values regarded as "reasonable" based on theory and microeconomic estimates. Hence the preference for the more time consuming approach of calibration based on microeconomic evidence.

Providing parameters that fit the facts and are relatively simple to estimate for different countries is particularly important for a policy model such as GEM, as there is a premium on making the model both fit the facts and look at a range of issues across many different countries. Accordingly, the GEM team has been working on using a Bayesian approach to estimate the model's parameters. Bayesian estimation is the main alternative to the classical approach. The key difference between the two is that in the Bayesian framework the analyst specifies his or her initial view about the value of each parameter and the certainty with which this view is held before estimating the model. This prior information is combined with the evidence contained in the data to obtain final estimates of the model's parameters. Initial views about parameters can thus be used to improve the accuracy of estimates of key elasticities on which the underlying data have limited information, and the resulting estimates can be used to create useful parameterizations for simulations.

In many respects, Bayesian estimation is simply a mechanized version of the approach currently used to calibrate models, with its combination of using prior information obtained from outside sources, such as microeconomic studies, with judgments about how well the model fits the data. The great advantage is that, once the Bayesian routine has been established, it can be used to rapidly provide plausible parameterizations across countries. For example, priors can be used to ensure that deep underlying elasticities across a range of countries could be very similar (on the basis that human nature is relatively invariant across countries) while parameters associated with the speed of adjustment, which are more dependent on the particular institutional arrangements in a country, can be derived mainly from the data. Indeed, Bayesian techniques have already been used to generate plausible, albeit preliminary, parameter estimates for a simple closed economy model of the United States, but have not yet been extended to the full GEM.

Figure II-4. Dynamic Responses of GEM Compared to Large Forecasting Models
(percent deviation from baseline)

Euro Area

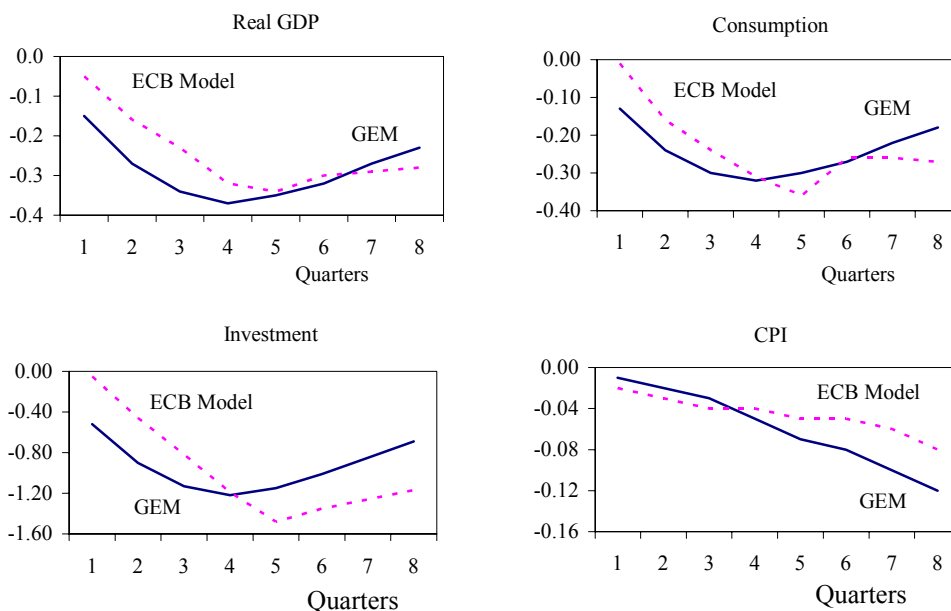

United States

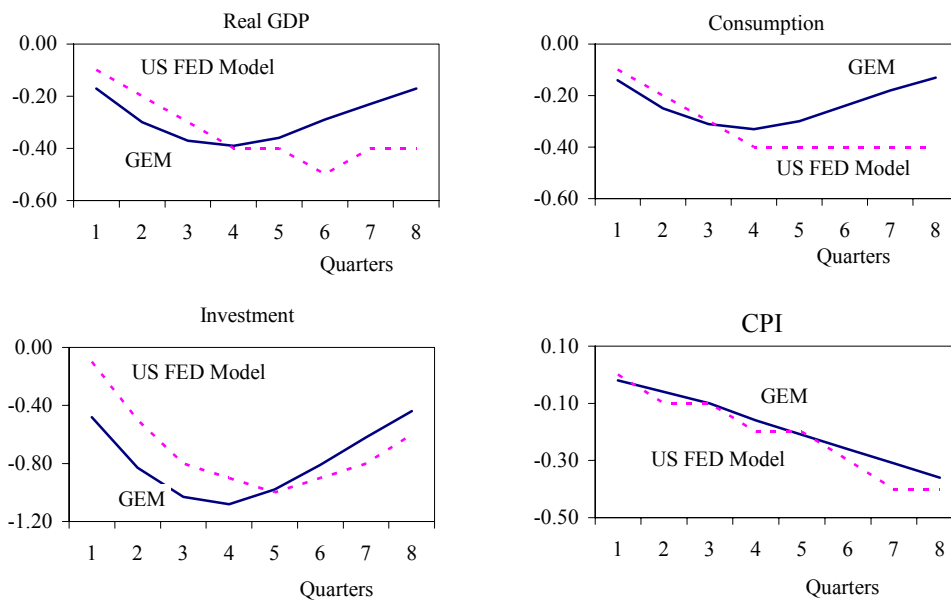

Source: Staff calculations based on information supplied by the Federal Reserve Board and European Central Bank

Figure II-5. Dynamic Responses of GEM Compared to a VAR

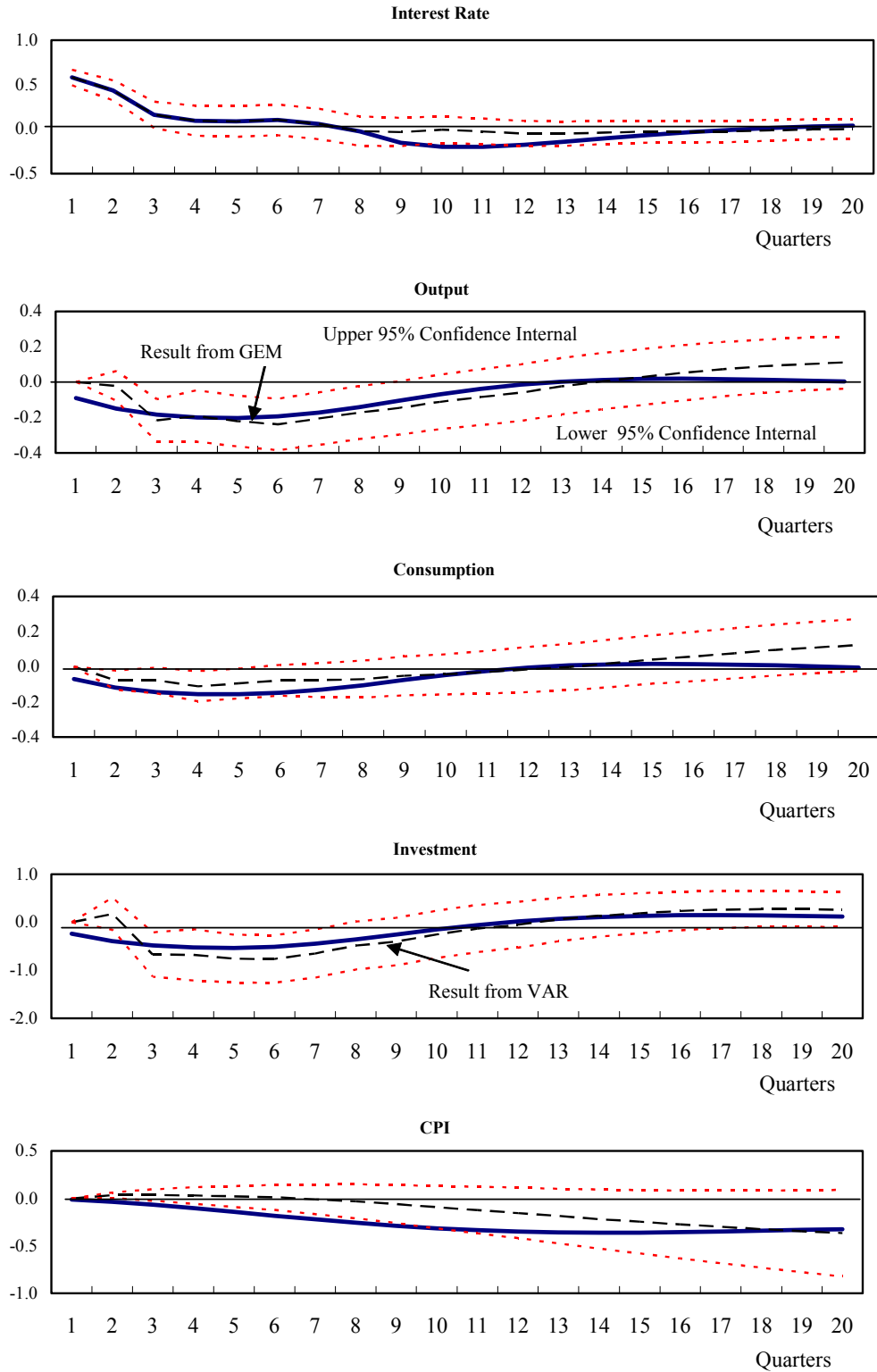

Source: Altig and others (2003) for VAR, Staff calculations for GEM.

Strengths and Weaknesses of GEM

19. One of the great advantages of GEM compared to earlier types of models is that it can provide evaluations of policies in a general equilibrium setting, thus taking account of the full range of effects across equations. As the model is built from explicit microeconomic foundations, a change in one of the deep parameters in the model can have effects across a wide range of relationships. These complex interrelationships help to identify economic linkages more precisely, providing a stronger framework for analysis that can generate new insights as well as encouraging closer links between Fund researchers and the academic community. This is particularly important at the early stage of creation of a paradigm, when these insights have not been fully incorporated into mainstream analysis, and help explain the enthusiasm GEM has created in academia.

20. As an example of unveiling linkages, consider a policy that increases competition in the labor market (discussed in more detail in Section III). The most obvious effect is that the market power of workers diminishes, increasing output and, as more goods need to be sold to the rest of the world, depreciating the real exchange rate. The effects on domestic output depend crucially on the response of hours worked to a change in real wages, while the international effects depend on the degree to which home and foreign goods are substitutes. As these parameters are explicitly identified in GEM, the consequences of different assumptions about them can be easily qualified, while in MULTIMOD these elasticities were combined with others in reduced-form relationships. In addition, an important new insight coming from GEM is that more labor market competition reduces nominal inertia. This is because it increases the costs firms accrue when wages deviate from their flexible-price level. Such an effect could not have been captured in models such as MULTIMOD with a fixed Phillips curve relationship.

21. Another example is the impact of industrial country exchange rate volatility on emerging market countries (see IMF, 2003). The flexibility of GEM meant that the effects of structural differences in the emerging market on the impact of such volatility could be explored, including alternative exchange regimes, levels of openness, bilateral trade patterns, levels of debt, and exchange rate pass-through. Insights from this exercise include the importance of the exchange rate regime and degree of domestic exchange rate pass-through on the associated output volatility, effects that depended crucially on the integration of supply, demand, trade, and international asset markets in GEM.

22. A second advantage of GEM is that the costs and benefits of a policy can be evaluated in a more sophisticated manner. As the model is derived from explicit maximization of profit and utility, one can evaluate policies in terms of their effects on consumer welfare. The advantage of welfare is that it measures the gain to consumers, the ultimate objective of economic activity, and provides a measure of the “best” policy as well as a way of comparing the effects of different policy options. By contrast, in MULTIMOD and similar models benefits were analyzed using more ad hoc measures. For example, monetary policy was generally evaluated in terms of the variability of real output and inflation.

23. The large size of GEM is an advantage in this respect. Broadly speaking, policies are most useful when they can help reduce economic distortions. As GEM includes a relatively

large number of such distortions—such as monopolistic competition, sticky prices, and sluggish adjustment of trade volumes—the potential role for policies to improve welfare is commensurately strengthened. That said, to date it has only been possible to evaluate welfare benefits in small models with simple structures often comprising only one country. This is because of the large computing power needed to solve for a dynamic path with the nonlinear functions needed to calculate welfare. Given the rapid progress in both computing power and solution techniques, however, it is reasonable to expect that full welfare calculations of dynamic simulations will be possible with GEM in the near future.

24. Even without full welfare analysis, however, GEM can still provide new insights. As discussed further in Section III, the appropriate monetary rule depends importantly on how potential output is evaluated. A model such as GEM can provide a more accurate calculation of the output gap by incorporating the impact of shocks on the path of aggregate supply. Policy rules using this output gap can then be compared with those using a more traditional approach in which potential output is assumed to change slowly over time, providing insights into the degree to which monetary policy makers should focus on identifying the supply-side implications of disturbances in assessing monetary conditions.

25. It is important to recognize that moving to a model with a tight theoretical structure also imposes limitations, at least in the short term. Accordingly, MULTIMOD remains a useful tool of analysis, although future development will cease and its use will presumably diminish over time. There are the usual growing pains associated with any new project, such as the need to gain more experience with versions of GEM comprising three or more countries. In addition, the need to create a large interlinked structure constrain theoretical specifications and hence model properties. For example, the use of a representative consumer means that the model is not currently suitable for analysis of income distribution. The need for theoretical consistency can also complicate the addition of new features. For example, the current version of the model does not generate realistic short-term tax multipliers, although this is an area of active development. As discussed further in Section IV, one of the main theoretical approaches to creating such multipliers is to assume that consumers have finite lives. Another implication of finite lives is that consumers' behavior depends on age and hence cannot be summarized by a single “representative” individual, which creates significant theoretical complications elsewhere.

26. Finally, calibration of GEM is currently time consuming. This is partly because the concepts in the model often do not dovetail with existing data. For example, it is not easy to split output into traded and nontraded goods or to determine the role of commodities and semi-finished components in production. In addition, changes in a coefficient generally affect several equations, with a complex effect on model properties. To date, calibrations have only been completed for three economies—the United States, the euro area, and the Czech Republic. Data sets that will help with calibration have been obtained for over twenty countries and regions, including a wide range of emerging markets as well as advanced countries, while experience with earlier calibrations are helping to make the process less time consuming.

III. HOW HAS GEM BEEN USED?

27. GEM simulations have already been used to provide insights on a range of issues. In particular, they have been incorporated into the staff's analysis in the analytic chapters of the *World Economic Outlook* and other work such as recent Board papers analyzing the impact of entry into European Monetary Union on EU accession candidates and the most recent U.S. Article IV Consultation, as well as in contributions to academic conferences and journals. In many cases these efforts have been combined, so that work originally used for (say) the *World Economic Outlook* has generated academic papers, while work originally prepared for academic conferences has provided the basis for analysis to assist the staff. Indeed, such dual uses ensure policy relevance and professional rigor. On the other hand, like MULTIMOD, GEM is not used to generate the Fund's forecasts. Rather, the *World Economic Outlook* exercise uses the expertise available on countries by aggregating projections from individual country desks.

28. This chapter discusses three such simulations, chosen to illustrate the value of GEM across a range of questions. Accordingly, each simulation focuses on a different type of shock and demonstrates a different model strength. The first simulation explores the impact of structural reforms that are assumed to raise competition in euro area labor and product markets to U.S. levels and illustrates how the microeconomic foundations of the model allow GEM to tackle issues on which earlier models provided little insight. The second asks how monetary policy rules should differ between industrial countries and emerging markets and illustrates how GEM can be used to evaluate the impact of policies in more sophisticated ways. The third examines the consequences of oil price hikes on industrial countries and illustrates how GEM's flexible structure can be used to provide deeper analysis of an issue. These simulations do not exhaust the work using GEM. Other exercises using GEM which are not discussed in this section include an analysis of external developments in the United States in the late 1990s (Hunt and Rebucci, 2003) and the impact of industrial country exchange rate instability on emerging markets (IMF, 2003).

Measuring the Benefits of Raising Euro Area Labor and Product Market Competition

29. Structural reforms are becoming an increasingly important element in Fund policy advice, as it has become clear that there is a close connection between macroeconomic policies and the underlying economic environment. While the issues differ across regions, in western Europe the focus has been on ways to increase competition in domestic markets. Indeed, European leaders at a number of recent summits have embraced this objective, most notably at Lisbon in 2001.

30. Greater competition in product and labor markets clearly benefits an economy through ensuring more efficient allocation of resources and making markets more flexible in the face of shocks. However, it has proved difficult to use macroeconomic models to provide quantitative assessments of these gains. This partly reflects difficulties in measuring such concepts as levels of competition or institutional quality, as well as the issue of how reduced form-relationships identified by regression analysis might change if policies are directed at improving them—another example of the Lucas critique.

31. Work using policy models loosely tied to theory has relied heavily on microeconomic studies, which provided estimates of how regulatory changes would impact a range of variables that were then incorporated exogenously in model simulations. A good example of such an approach is the 1997 OECD Report on Regulatory Reform (OECD, 1997). Detailed microeconomic studies were performed that estimated the benefits of comprehensive reform in five highly regulated industries comprising around 20 percent of output in the United States, Japan, Germany, France, and the United Kingdom. The studies measured how such reforms would reduce prices of these goods, raise productivity in the sector, and affect employment. The aggregate impacts across all five sectors were then fed into a macroeconomic model by exogenously changing labor efficiency, employment, prices, and (through the erosion of rent sharing) wages. The main lesson from these simulations was that if the gains in labor efficiency were not fully captured by higher wages in the affected sectors, modest additional increases in output could occur elsewhere in the economy. Focusing the euro area, the results suggest that the initial increase in real GDP found in the microeconomic studies of 4 percent could rise by a further percentage point. However, the bulk of the effects derive from the initial microeconomic studies, with limited addition information coming from the macroeconomic model simulations.

32. In GEM, lowering a single parameter, namely the markup of prices over marginal cost, can simulate the impact of increasing product market competition, with a parallel structure in labor markets. This illustrates the advantages of the strong microeconomic foundations of the model. In particular, GEM assumes an explicit industrial organization structure, namely monopolistic competition. Firms use their monopolistic power to restrict output and increase profits, reducing welfare and generating a markup of prices over marginal cost. By decreasing producers' market power, greater competition in goods markets reduces markups and boosts output as lower goods prices raise real wages and increase demand for products. The set up in the labor market is analogous except the boost comes from lower costs to firms. Increasing competition is thus equivalent to lowering the markup on prices and wages. Furthermore, it is possible to calibrate this parameter relatively easily as these markups have been estimated in the microeconomic literature.

33. Accordingly, a two country version of GEM using a relatively streamlined structure (Figure II-2) was created comprising the euro area and the rest of the world, parameterized as the United States (Bayoumi, Laxton, and Pesenti, 2003). Based on cross country empirical evidence for the 1980s and 1990s, economy-wide price and wage markups were set at 35 and 30 percent in the euro area, respectively, and 23 and 16 percent in the United States. Simulations lowering euro area markups to U.S. levels produced the following results (for more details, see Box III-1):

- *Euro area output and welfare rises significantly* (Table III-1). Euro area real GDP rises by 12½ percent and hours worked by 8 percent. The increase in welfare is smaller but still notable, equivalent to a 2½ percent rise in steady state consumption as some of the benefits from greater consumption are partly offset by more work, demonstrating the value to using welfare-based criteria to evaluate policy changes. About two-thirds of these increases in output and welfare are attributable to product market reforms, and the remainder to more competitive labor markets. These benefits are relatively invariant to alternative values of deep parameters.

- *Reforms increase investment rapidly, but the benefits to consumption are more delayed* (Figure III-1). By diverting resources, the investment boom generates a significant lag between the implementation of reforms and a sustained increase in consumption, particularly if the reforms are not fully credible.
- *There are positive spillovers to the rest of the world.* The need to sell the increased output leads to a real depreciation of euro, improving the terms of trade of the rest of the world. In the base case simulation, consumption in the rest of the world rises by about 1¼ percent. As labor effort is largely unaffected, welfare also rises by the equivalent of 1¼ percent of steady state consumption. The size of these spillovers are sensitive to the assumed values of a range of deep parameters.
- *Structural reforms ease the task of monetary policy makers in the euro area.* Greater competition, particularly in labor markets, reduces nominal rigidities in the euro area. This greater nominal flexibility reduces the inflationary costs of stabilizing output thereby making it easier to use monetary policy in a counter-cyclical manner.

Should Monetary Policy Rules Differ Between Industrial Countries and Emerging Markets

34. Ever since the rational expectations revolution, monetary policy has been analyzed in terms of the impact of alternative rules rather than the impact of discretionary responses to particular circumstances. Reflecting the importance attached to the public's assumptions about future policies, rational expectation models create an important distinction between underlying policy rules and discretionary deviations from this path. The long-term impact of monetary policy is best summarized by comparing alternative rules that are fully understood by the public.

35. The most famous of these policy rules was introduced in the 1980s by John Taylor, who argued that a reaction function in which the short-term interest rate responded to movements of inflation from a desired value and to changes in the output gap (i.e., the difference between actual output and its underlying trend) was a good summary of how U.S. monetary policy had been conducted (Taylor, 1993). This "Taylor rule" and variations that (for example) replace current inflation by expected future inflation and/or add a term to take account of the fact that central banks appear to smooth interest rate changes continue to form the basis for most analysis of monetary policy under flexible exchange rates.

36. Taylor also provided the framework for assessing alternative monetary rules based on the volatility of inflation and output. Recognizing that the primary objective of monetary policy is to provide an anchor for inflation expectations, he argued it is crucial for the policy rate to react sufficiently strongly to inflationary developments to raise real interest rates and deflate the economy. A secondary objective was to provide support to the real economy by reacting to cyclical developments. Within these constraints, the job of the monetary policy

Box III-1. GEM Simulations of the Benefits of Greater Euro Area Competition

GEM simulations increasing competition in euro area product and labor markets to U.S. levels reported in Bayoumi, Laxton, and Pesenti (2003) imply that such reforms would provide a wide range of benefits to the euro area and the rest of the world (Table III-1). In particular:

- *Euro area real GDP rises by 12½ percent*, fueled by a 20 percent increase in the capital stock and an 8 percent increase in hours worked. About two-thirds of these benefits to output are attributable to product market reforms, and the remainder to labor markets.
- *The percentage rise in euro area consumption is only about two-thirds of the percentage increase in GDP*, reflecting both the large rise in investment and the real depreciation of the euro as higher output in the euro area lowers the real exchange rate.
- *The rest of the world benefits*, as the real depreciation of the euro makes consumers elsewhere richer and higher euro area demand increases imports from the rest of the world. In particular, foreign consumption rises by 1.3 percent, about one-sixth of the increase in the euro area.
- *The increases in welfare are substantial*. Welfare rises by the equivalent of 2½ and 1¼ percent of steady state consumption in the euro area and the rest of the world, respectively. Welfare rises less than consumption in the euro area because of higher hours worked, emphasizing the value of using a welfare-based measures of benefits as opposed to using (say) the increase in output or consumption.
- *Euro area wages and prices become more flexible*. As an illustration, the sacrifice ratio—defined as the output cost of permanently lowering inflation by one percentage point—falls from two to under one-and-a-half. This makes it easier for the European central bank to use monetary policy to stabilize the cycle.
- *The increase in domestic output is relatively invariant when key parameters are changed* (except that the impact of labor market reforms depends on the response of hours worked to movements in real wages), but the size of the spillovers to the rest of the world is quite sensitive to the chosen values for a number of important parameters, most notably the substitutability of home and foreign goods.
- *Dynamic simulations indicate that reforms increase investment rapidly, but the benefits to consumptions are more delayed* (Figure III-1). After an initial boom funded from abroad, consumption falls below baseline for a time as investment booms and real interest rates rise before increasing as capacity rises. If the reforms are not fully credible, the consumption response becomes further elongated.

To explain the key linkages behind these results, it is useful to focus initially on product markets. Increased competition across firms raises desired output, thereby increasing the demand for investment and labor. There is an investment boom as it is less costly in the long run for firms to buy more capital than hire more labor, as capital can be produced while the supply of labor is less flexible. Higher output at home reduces local prices compared to their foreign counterparts, and this real depreciation boosts consumption abroad by making foreign consumers wealthier. In addition, domestic price stickiness is reduced as greater competition increases the loss to the firm allowing prices deviate from their desired level if prices were fully flexible.

More competitive labor markets produce similar effects, but with a larger impact on hours worked and a smaller effect on domestic output and international spillovers due to different microeconomic linkages. These differences emanate from the fact that labor reforms work by lowering real wages and raising hours worked while product market reforms affect output and final prices directly. Because the main impact is on labor markets, the effect on output is muted while lower real wages further diminish the international spillovers as the home country remains more competitive.

The simulation provides a number of policy conclusions. In particular, there are large domestic gains from reforms to increase competition in both product and labor markets, including by reducing the sacrifice ratio, and the rest of the world also benefits. However, the results indicate that advantages for local consumers come on stream only after a delay, particularly if the reform program is not fully credible. Such a pattern, which seems consistent with experience, may explain part of why such programs are difficult to initiate politically. These GEM simulations are simple to run, produce plausible benefits compared to earlier work, and avoid the need for expensive and complex microeconomic studies of the impact of specific reforms.

Table III-1. GEM Estimates of the Long-Run Effects of More Competition-Friendly Policies in the Euro Area
(percent deviations from baseline)

	Product Market Reforms	Labor Market Reform	Both Reforms
<i>Euro Area:</i>			
GDP	8.6	3.5	12.4
Consumption	4.9	3.3	8.3
Investment	17.0	3.5	21.2
Labor Effort	4.5	3.6	8.3
Real Exchange Rate	4.2	1.1	5.3
Utility 1/ Sacrifice Ratio	1.9 2.0⇒1.7	0.9 2.0⇒1.7	2.4 2.0⇒1.4
<i>Rest of World:</i>			
GDP	0.7	0.2	0.8
Consumption	1.0	0.3	1.3
Investment	0.5	0.1	0.7
Labor Effort	0.1	0.0	0.2
Utility 1/	0.9	0.3	1.2

Source: Bayoumi, Laxton, and Pesenti (2003)

1/ Percentage increase in terms of steady-state consumption.

makers was two-fold. First to identify the most efficient monetary rules, in the sense that it provided the lowest level of instability in (say) inflation for any given level of output volatility—the so-called Taylor efficiency frontier (Figure III-2). Second, choosing the preferred and most robust rule from this frontier given their own preferences between these two sources of macroeconomic instability.

37. This framework has been the workhorse for the large literature on monetary analysis for the last decade. The vast majority of the analysis has been on industrial countries, and even within this most work has focused on closed economy models of the United States. It has encompassed everything from three equation representations of monetary policy to large models such as the Federal Reserve’s FRB-US. In addition to examining the best options for a given model, there has also been work on which rules provide robust outcomes when parameters are uncertain or the analysis incorporates models with different theoretical structures. One general conclusion from this literature is that in large countries the monetary authorities should respond to both inflation and the output gap. Another is that the monetary authorities should put more weight on inflation and less weight on the output gap as the country becomes more open to trade, but that there is little benefit from including the exchange rate in the policy rule. Finally, there appear to be significant gains from smoothing interest rate changes over time, consistent with empirical evidence that policy makers indulge in this practice.

Figure III-1. Dynamic Effects of More Competition-friendly Policies in the Euro Area
(Anticipated and Perfectly Credible)

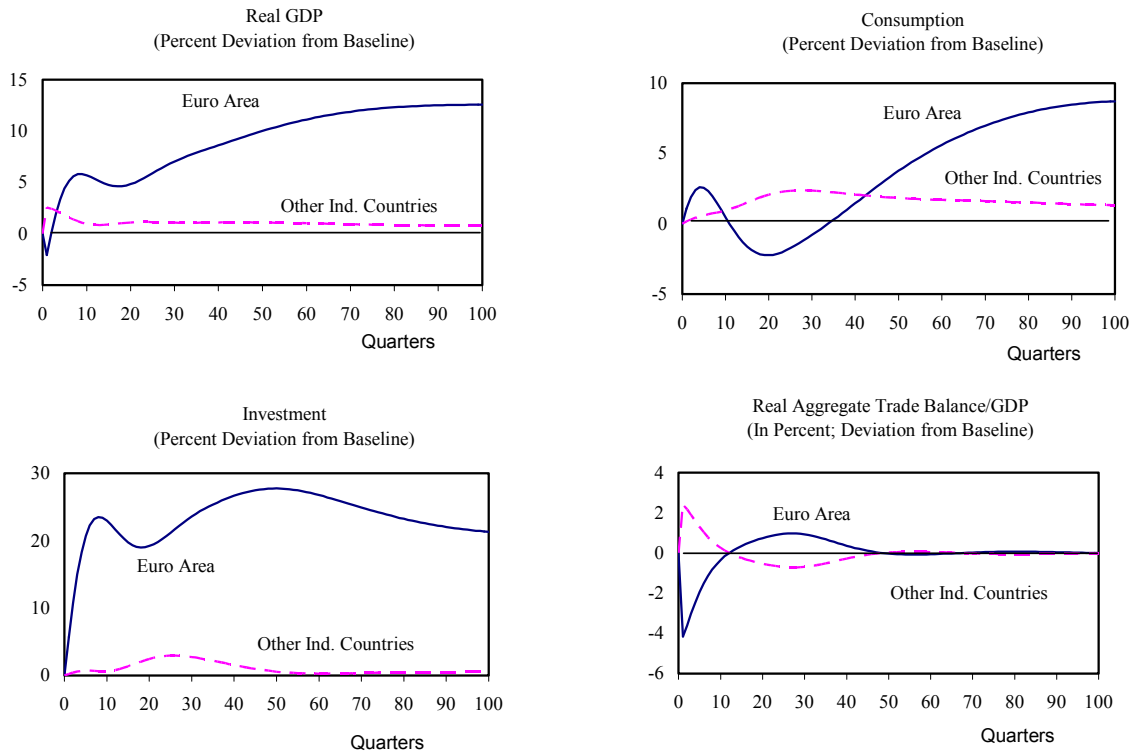

Source: Bayoumi, Laxton, and Pesenti (2003)

38. GEM was used to examine how monetary rules in small open emerging markets might differ from those for large industrial countries (Laxton and Pesenti, 2003). The paper illustrates how the model can extend existing analyses through better measurement of concepts and benefits.³ A two-country version of GEM was created comprising the euro area and the Czech Republic, with the euro area generating 95 percent of total GDP. To capture the subtleties of the Czech Republic's relationship with the euro area, which include importing components and reexporting the finished product plus a trend appreciation of the real exchange rate attributed at least in part to Balassa-Samuelson effects, the model included trade in intermediate goods, traded and nontraded sectors, and distribution (Figure II-3).

39. Simulations with random shocks broadly corresponding to the historical record were then introduced and alternative monetary rules for the Czech Republic compared to those for the euro area. The results (discussed in more detail in Box III-2) are that:

³ As in earlier models, monetary policy in GEM affects the economy through the impact of changes in the real interest rate on consumers and producers, and depends upon the interest-sensitivity of spending as well as the impact on the exchange rate.

Figure III-2. Taylor Tradeoff In Monetary Policy Analysis

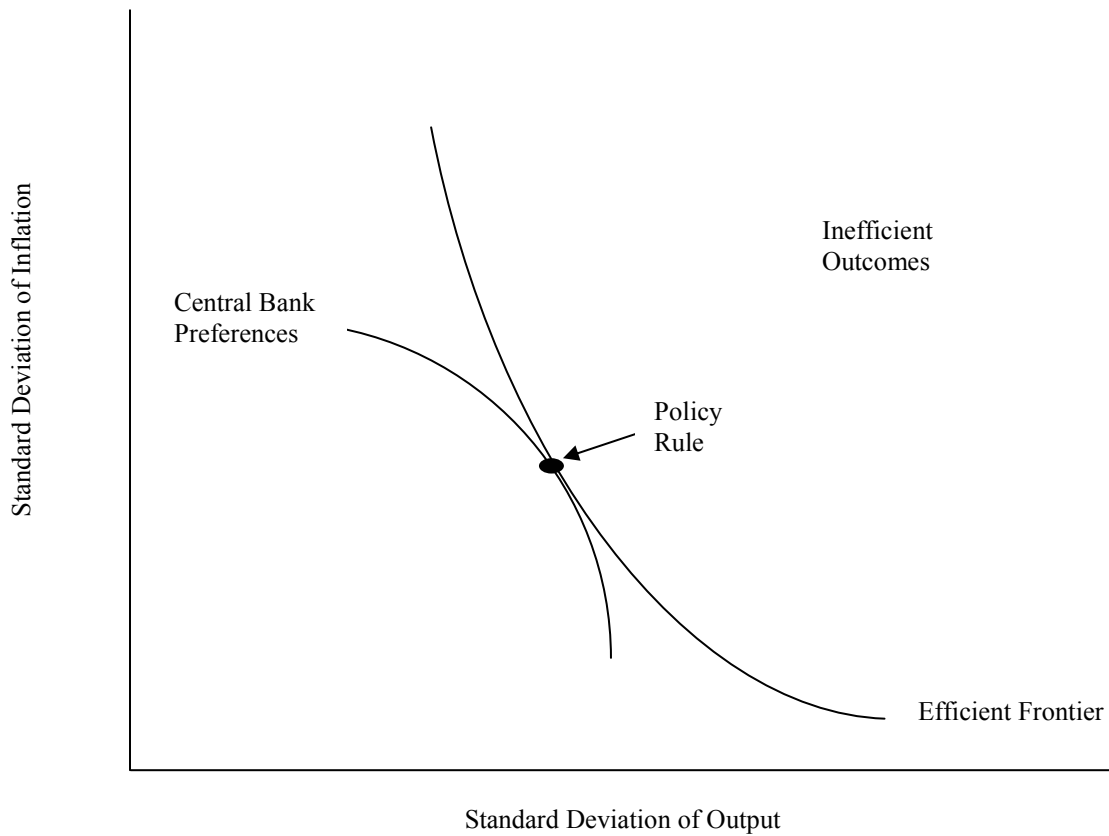

- *GEM broadly reproduces earlier results for the euro area using a Taylor framework.* This is comforting as it implies that despite its strong theoretical structure GEM is able to fit existing stylized facts for industrial countries in this well-researched field.
- *The optimal monetary policy for the Czech Republic depends crucially on how potential output is measured.* Using the conventional assumption that potential output is a slow-moving series, policy makers should only respond to inflation, and should ignore the output gap. This is mainly because of the greater importance of aggregate supply shocks in emerging markets, disturbances to which such a measure of the output gap provides a perverse signal for monetary policy. The output gap, however, becomes a much more useful indicator if the impact of aggregate supply shocks on underlying supply potential is immediately incorporated into the measured output gap (as can be done in GEM but not in earlier models).

Box III-2 Using GEM to Analyze Monetary Policy Rules

A two-country version of GEM was created comprising the euro area and the Czech Republic, with the euro area generating 95 percent of total GDP (see Laxton and Pesenti, 2003). To capture the subtleties of the Czech Republic's relationship with the euro area, which include importing components and reexporting the finished product as well as a trend appreciation attributed at least in part to Balassa-Samuelson effects, the model included trade in intermediate goods, traded and nontraded sectors, and distribution (Figure II-3). For the euro area, which approximates a closed economy, the tradeoffs between alternative policy rules corresponded closely to those found by others using earlier large models (the figure illustrates the tradeoff coming from GEM). This is comforting, as it implies that despite its strong theoretical structure GEM is able to fit existing stylized facts for industrial countries in this well-researched field.

The main focus of the GEM work, however, was examining policy rules for small emerging markets which are extremely open to trade such as the Czech Republic. This is an under-researched area that GEM is particularly well designed to examine, as differences in underlying economic structure can affect monetary responses through the unified theoretical structure. As can be seen in the figure, a rule that is robust for a large and relatively closed economy such as the ECB produces a high level of inflation variability in an emerging market. Further analysis indicates that a more robust rule for the emerging market involves a greater focus on inflation. Hence, the Czech National Bank should put a much higher weight in their rule to responding to inflation and a negligible weight on the output gap (and, it turns out, the exchange rate). This work was recently extended to examine the macroeconomic effects of EU accession countries entering EMU. As reported in Board paper SM/04/2, adoption of the euro might be expected to have some macroeconomic costs compared to a well-designed monetary framework, but these effects have to be set against the microeconomic benefits associated with a single currency.

The results for the Czech Republic represent a magnified version of the conclusion from the existing literature that more open industrial economies should have rules that focus more on inflation. This amplification in GEM comes from two important differences in economic structure between the Czech Republic and industrial countries. First, emerging markets such as the Czech Republic have high levels of wage-price flexibility, so that there is less need for monetary policy to respond to aggregate demand shocks that move output temporarily from potential. Second, such countries are subject to a higher proportion of aggregate supply shocks. As these shocks have consequences for the long-term path of output, inflation gives a better signal to the monetary authorities than conventional measures of the output gap which assume potential output adjusts slowly.

Further analysis using GEM indicates that Czech monetary policy can be improved by using a more sophisticated measure of the output gap. The theoretical structure in GEM allows the replacement of a conventional slow-moving measure of potential output by the level of output that would obtain if prices were fully flexible but adjustment costs remained on real variables such as the capital stock (this would be much more difficult in older models, as their structure does not provide a clear distinction between real and nominal rigidities). GEM simulations indicate that if the Czech monetary authorities could calculate this more sophisticated measure of the output gap then they should include the output gap in the monetary rule. Two policy messages come out of this exercise. The first is the importance of monetary policy makers rapidly taking a view on the sources of disturbances to the economy, particularly in emerging markets which are more subject to frequent supply disturbances. Second, because estimating the consequences of shocks on potential output is inherently relatively uncertain, small, open economies subject to large supply shocks should generally have monetary rules that focus more on changes in inflation.

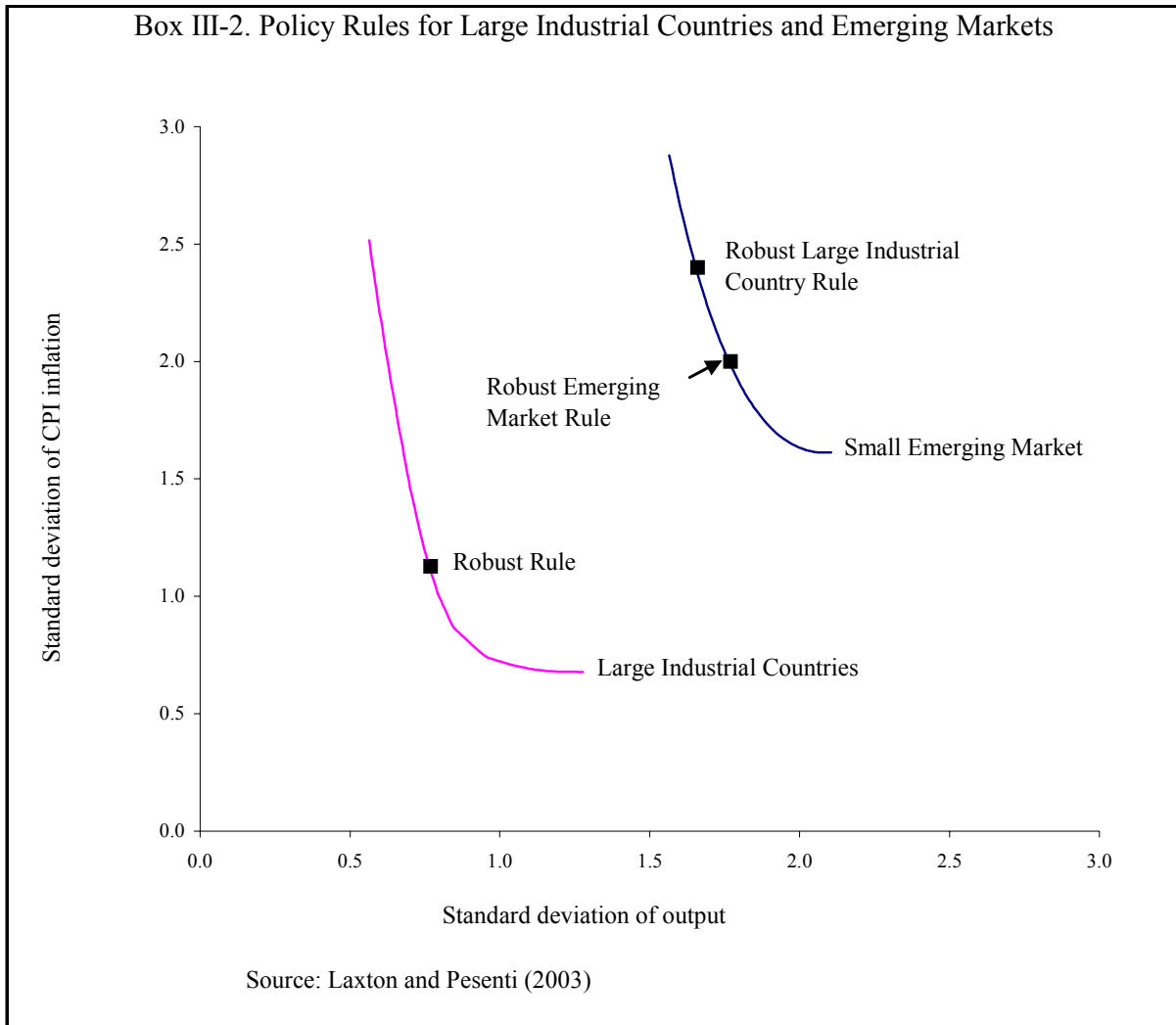

40. These results emphasize the importance of monetary policy makers rapidly taking a view on the sources of disturbances to the economy, particularly in emerging markets which are often more subject to supply disturbances. That said, because estimating the consequences of shocks on potential output is inherently uncertain, small, open economies subject to large supply shocks should generally put a higher weight on inflation in evaluating the monetary stance than larger, more closed economies where aggregate demand disturbances are more prevalent.

41. Subsequent work using GEM has examined the welfare-maximizing monetary rule. Unfortunately, the computation burdens implied by the needed solution techniques have constrained this analysis to a single country that is closed to trade. Preliminary results suggest that consumers' utility is maximized when the monetary authority responds to inflation and real activity, as in the conventional Taylor rule. However, they also suggest that policy makers should focus mainly on the rate of change of the output gap rather than its level because of the uncertainties associated with measuring the level of potential output. Hence, this approach has significant implications for the form of the monetary rule. The

results also indicate that there are significant welfare benefits to adopting a sound monetary framework, in contrast to earlier work using models with fewer types of distortions, although the gains are smaller than those typically found from substantive changes in structural policies (see Galí, Gertler, and López-Salido, 2002).

The Impact of Higher Oil Prices

42. Oil prices continue to be a significant source of volatility for the global economy. Sustained movements in the dollar oil price of 10 percent or more, which trigger a new baseline for Fund analysis, remain relatively common over short periods of time. New baselines have resulted in last minute changes to the forecasts contained in the *World Economic Outlook* on several occasions over recent years, as well as affecting many other aspects of the Fund's work, including program design. Oil is the only commodity to have such a systemic impact, although other commodities are important for individual countries. Indeed, while the dependence of industrial countries on oil has diminished somewhat as manufacturing sectors have shrunk in proportion to the rest of the economy, the opposite has occurred in many emerging markets. In short, understanding the impact of changes in oil prices on activity is a key input into multilateral surveillance.

43. The Research Department published a study in 2000 of the impact of oil prices on the global economy, which included ready reckoners of the impact of a permanent \$5 per barrel hike in oil prices on activity across a range of industrial and developing countries after a year (IMF, 2000). The results for emerging markets, poor countries, and oil producers came from the inputs of country desks, while those for the industrial countries were based on MULTIMOD simulations. These simulations incorporated the effects of oil price hikes through a number of channels. The impact on external balances was fully integrated in the model, being based on data on oil trade which is identified separately in the MULTIMOD database. The impact on potential output, however, was implemented through changes to total factor productivity. As shown in Table III-2, the results suggested that a permanent \$5 hike in oil prices would lower output after a year by 0.4 percent in the United States and euro area and 0.2 percent in Japan and other industrial countries, and would be accompanied by significant impacts on inflation and the trade balance.

44. The GEM simulations of oil price hikes illustrate the advantages of having a flexible model structure. Rather than approximate the effect of an oil price hike through altering the level of productivity, a commodity sub-model was constructed that is fully integrated into the rest of GEM but can be turned on and off depending on the issue at hand. The commodity (hereafter assumed to be oil) is produced using labor, capital, and land, a separate factor of production which explains why production occurs in some places and not others. Oil is then traded between countries and consumed by firms and individuals, so oil disturbances affect producers and consumers. Particular attention was placed on incorporating important elements of the global oil market into the commodity model. OPEC's market power was taken into account by assuming that oil producers are monopolistic competitors, so that oil price hikes can be triggered by an increase in market power due to greater compliance of individual OPEC members with production quotas. The limited pass-through of world oil

Table III-2. MULTIMOD: Impact of a Permanent \$5 a Barrel Increase in Oil Prices after One Year (percent)

	Real GDP	CPI Inflation	Trade Balance 1/
United States	-0.4	0.5	-0.1
Euro Area	-0.4	0.5	-0.1
Japan	-0.2	0.2	-0.2
Other Industrial Countries	-0.2	--	0.2

1/ Percentage Points of GDP

Source: IMF (2000)

prices to domestic prices due to specific taxes and other costs is modeled by assuming that oil passes through a distribution sector before being used by firms or consumers. Finally, while the long-run demand for oil and gas is quite sensitive to the real price in the long term, it is assumed to be extremely costly for firms to adjust their oil use in the short run. Calibration used earlier analysis of the oil market, in particular the long-term consequences of the oil prices hikes of 1974 and 1979.

45. The commodity model has been used to repeat the earlier ready-reckoner exercise using GEM's more integrated theoretical structure, as well as to produce simulations of the impact of oil price hikes in U.S. growth reported in last year's U.S. Article IV Selected Issues paper. Figure III-3 suggests that a permanent oil price hike of 20 percent (approximately equal to the \$5 hike used earlier) would reduce real output by some 0.4 percent for the United States and euro area and about half of this for Japan in a version of GEM involving the rest of the world and the United States, euro area, Japan, United Kingdom, and Canada, respectively. These differences across countries reflect variations in oil and gas production, trade, and the oil and gas intensity of production. In particular, the relatively large output losses in North America and small output losses in Japan reflect the latter phenomenon. These output effects are similar to those produced using extensive judgmental changes in MULTIMOD, but other responses are quite different. For example, the inflationary response is lower in the GEM simulations, consistent with the limited impact of oil price hikes on inflation in recent years, while the impact on the current account is larger, reflecting firms' inability to substitute away from oil in the short run.

46. Additional analysis using GEM indicates that the impact on output decreases rapidly as the price shock becomes more temporary, while the impact on the current account and inflation is less marked. More specifically, when it is assumed that half of the initial shock to oil prices is eliminated after a year, the impact on output is about one-fifth that of a permanent disturbance reflecting the rich theoretical structure. In particular, producers and

Figure III-3. GEM: Impact of a Permanent 20 percent Increase in Oil Prices After One Year

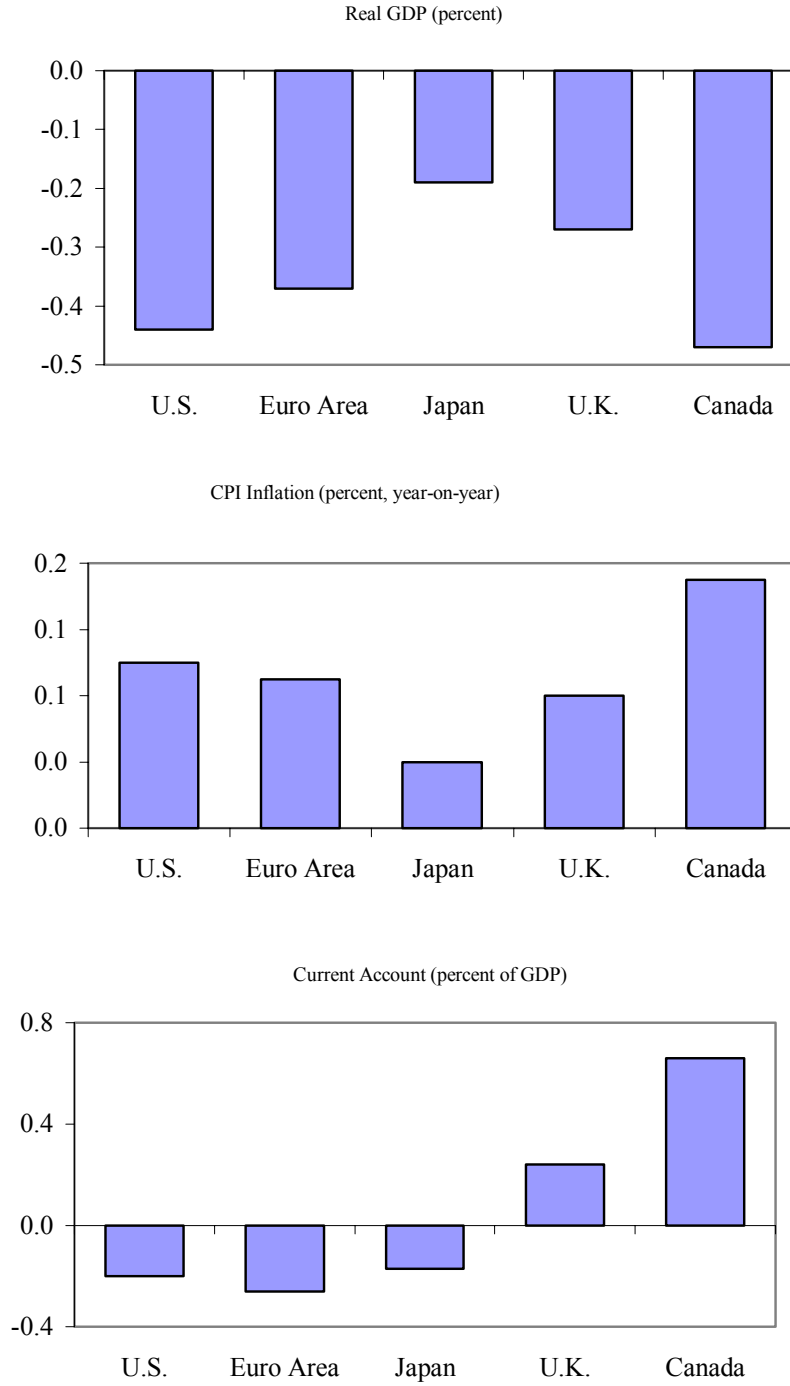

Source: Staff calculations

consumers feel less pressure to adjust knowing that the impact is not as permanent (Figure III-4). The impact on inflation, however, is similar across the two experiments, as it is dominated by the pass-through of the initial shock to oil prices into the CPI. The deterioration in the current account is somewhere between these two extremes, reflecting the fact that oil prices are significantly lower at the end of the first year in the temporary disturbance compared to the permanent one. The smaller impact on real GDP helps to explain why temporary spikes in oil prices, such as those that occurred over the 1990 Gulf war, appear to have had relatively little impact on global activity.

47. Thus far the model has been used to assess the impact of oil price hikes on industrial countries, in part because these effects have been the most heavily examined in other work. However, the framework can clearly be used to examine the consequences of change in oil or other commodity prices for other types of countries. In particular, the model can be used to look at the impact of oil or other commodity market disturbances for producers.

IV. CURRENT DEVELOPMENT WORK

48. GEM continues to be developed. Primarily, this reflects the enormous amount of work currently being done in academia using new-open-economy models to reexamine a range of issues, whose insights can provide ideas for how to improve GEM. In addition, as discussed earlier, the strong theoretical structure makes it complicated to add new features. This section discusses active development work on fiscal policy and international asset markets, including emerging market financing constraints. These areas have been chosen because of their relevance to the work of the Fund, in line with the overall philosophy underlying GEM.

Fiscal Policy

49. Fiscal policy remains an important macroeconomic lever for stimulating the economy and has been used actively over recent decades (see Figure IV-1). The main issue associated with this is the degree of Ricardian equivalence. Full Ricardian equivalence implies that changes in taxes and transfers have no impact on aggregate demand (as is currently the case in GEM). This is because consumers discount the future using the interest rates on government paper, so the value of tax cuts and subsequent tax increases offset each other, and people will fully offset a tax cut by higher saving. There are two main ways of creating realistic short-term tax multipliers. One is to assume that some individuals act as if they do not have access to financial markets, but rather vary their consumption in line with their disposable income. Such rule-of-thumb consumers can be easily incorporated into existing models and provide a way of examining income distribution issues but their behavior is highly mechanical, responding as much to a temporary tax cut as to a long-term one. The alternative is to assume that consumers have finite lives, adding a life cycle dimension to consumption. This provides more realistic consumption dynamics, with spending responding less to a temporary tax cut than a long-term one as predicted by the permanent income hypothesis, but at the cost of adding considerable theoretical complexity. In addition, the supply side effects of fiscal policy can be incorporated by adding distorting taxes. The explicit modeling of labor and product markets makes this an easy addition in GEM, in contrast to earlier models.

Figure III-4. GEM: Impact of a Permanent and Temporary 20 Percent Oil Price Hike After One Year
(Temporary Hike Assumes Half of Oil Price Increase Dissipates After One Year)

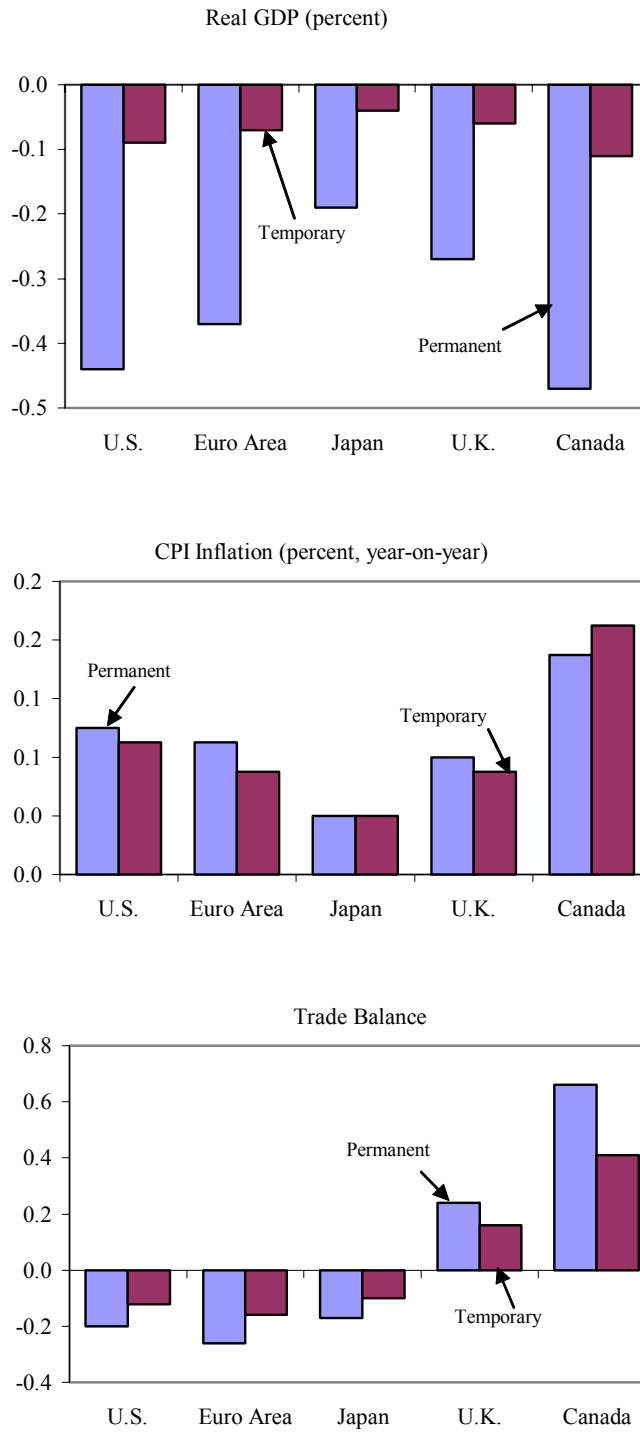

Source: Staff calculations

Figure IV-1. Structural Fiscal Balances in the Major Economic Regions
(General government as a percentage of potential output)

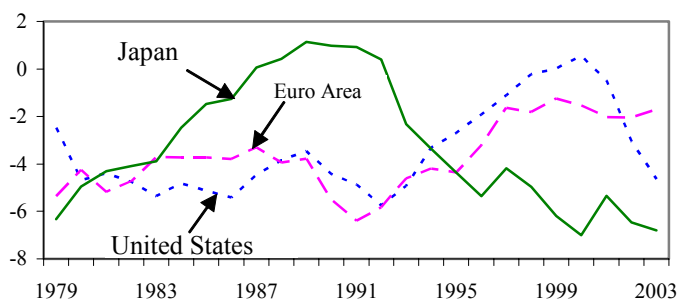

Source: *World Economic Outlook*

50. The plan is to adopt a two-track approach to incorporating fiscal policy into GEM. The main model will be altered to include distorting taxes and rule-of-thumb consumers, but not those with finite lives. Such a framework provides a reasonable way of dealing with changes in fiscal balances resulting from disturbances elsewhere in the model by taking account of the impact of automatic stabilizers. The second track involves developing an alternative version of the model that can be used to examine fiscal issues in more detail by incorporating finite-lived consumers with a simplified version of the rest of the economy based on the existing GEM framework. Adding such consumers with higher discount rates into the current GEM is extremely difficult, as its life cycle implications are inconsistent with the assumption that consumer behavior can be calculated from the actions of a single representative individual, greatly complicating the theoretical structure. Early prototypes of both models have been created.

International Asset Markets

51. Gross holdings of other countries' assets and liabilities have been rising rapidly across industrial countries in recent years as financial deregulation has reduced barriers to such transactions (Figure IV-2).⁴ This provides a new mechanism for transmission of the international cycle, as disturbances to future prosperity of domestic firms affect other countries through equity prices, reducing idiosyncratic shocks across countries and increasing the synchronization of the global business cycle.

52. International models with strong theoretical foundations have generally assumed either that international asset markets are complete or that they are limited to transactions in a single bond (Lane, 2000). Complete markets imply that movements in consumption across countries should be highly correlated, responding little to country-specific changes in

⁴ That said, typically only 5-10 percent of net wealth in G-7 countries is held in foreign assets (see IMF, 2001).

Figure IV-2. The Sum of International Assets and Liabilities in the G7
(Percent of GDP)

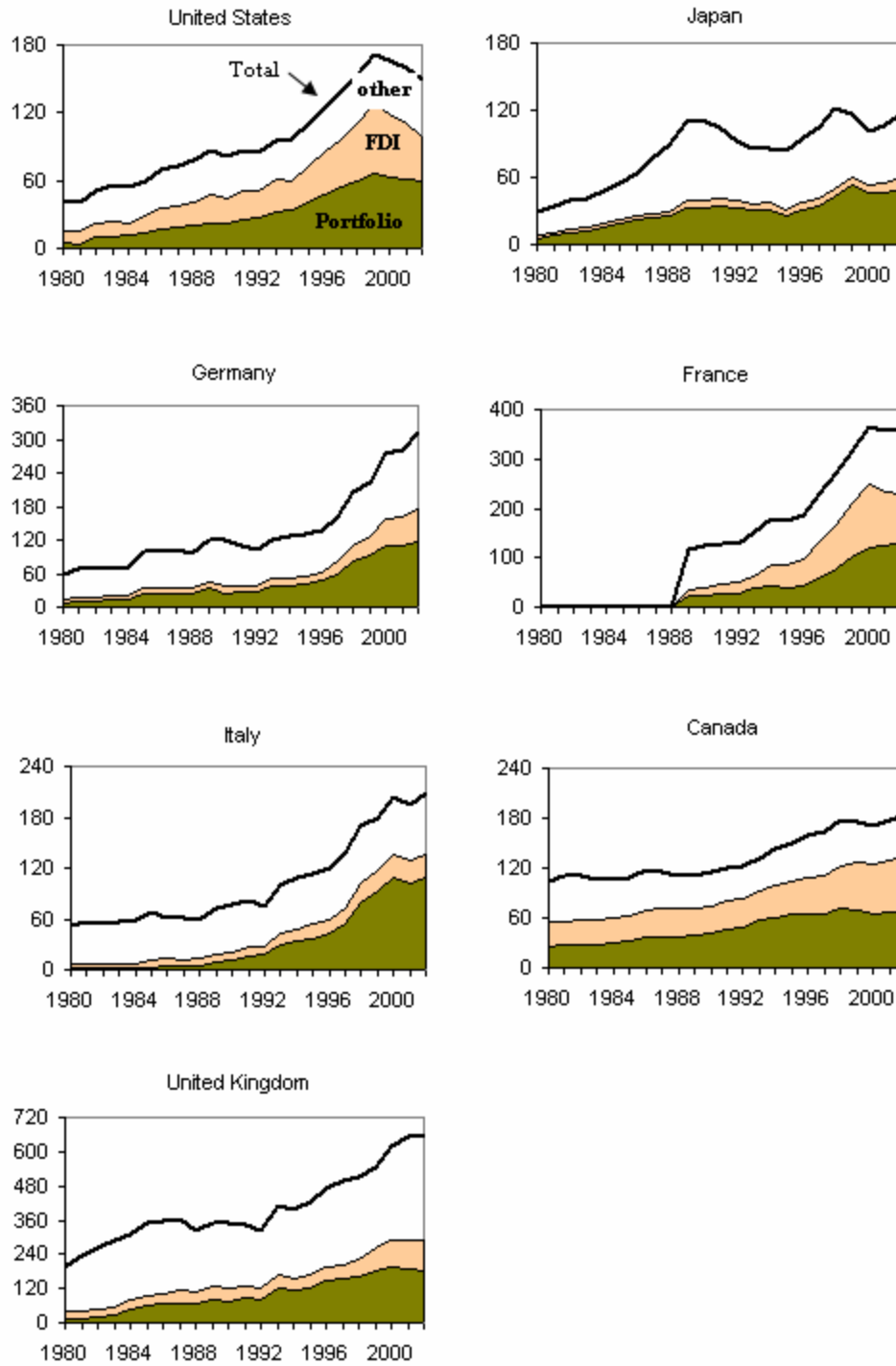

Source: *Balance of Payments Statistics*

domestic output, predictions that are so different from the existing evidence that few policy models have adopted this approach. Rather, they have tended to assume that one bond is the only asset traded across countries, which eliminates the need to model demand across different assets. This was the structure in MULTIMOD and in the current version of GEM. However, globalization of financial markets is making this structure increasingly problematic.

53. The staff has been developing a prototype theoretical model in which all countries issue domestic debt and equity that can be traded in international markets (similar work is also being undertaken by others). Different payment profiles create demand for each asset and, it turns out, a higher rate of return for equities than bonds. Home bias in holding assets is modeled by assuming that there is a cost to holding each asset, and these costs are higher for foreign assets than their domestic equivalents. These costs can also be used to explain the inability of emerging markets to issue debt in domestic currency by assuming that the costs of foreigners holding such debt is extremely high. Initial simulations indicate that the addition of a wider range of assets produce more realistic cross-country correlations of countries' consumption. Once the properties of this prototype model have been more fully investigated, the next stage will be to transfer the approach to GEM.

54. Another important issue in international asset markets is that for most emerging markets access is constrained, costly, and volatile (Figure IV-3). In addition, access for specific countries often becomes expensive or constrained just when they would normally want to borrow because of short-term domestic difficulties. Amongst other consequences, constrained access means that fiscal policies become pro-cyclical in economies where governments are highly dependent on foreign borrowing.

55. There has been a large amount of recent work in the new-open-economy macroeconomic and related literatures examining how to best characterize emerging market borrowing constraints. Much of this work has used the concept of the financial accelerator (Bernanke, Gertler, and Gilchrist, 1999). The cost of borrowing for a firm is inversely related to its net worth, so borrowing is increasingly difficult when the firm faces adverse shocks.⁵ This provides a reason why balance sheets matter for monetary policy transmission. It has been used to model domestic financial markets and banking systems, and has also been transferred to the analysis of foreign borrowing by emerging markets, with the main issue being how to define net worth. Work on adding a financial accelerator to GEM is proceeding, with a particular focus on the consequences of limited access of emerging markets to international financial assets.

⁵ Other work has used the same basic structure, but has focused on sudden stops in funding by assuming that countries can borrow up to the value of its collateral but not beyond, so that there is a change in behavior when the country hits its borrowing limit (Hart and Moore, 1994).

Figure IV-3 Capital Constraints for Emerging Markets

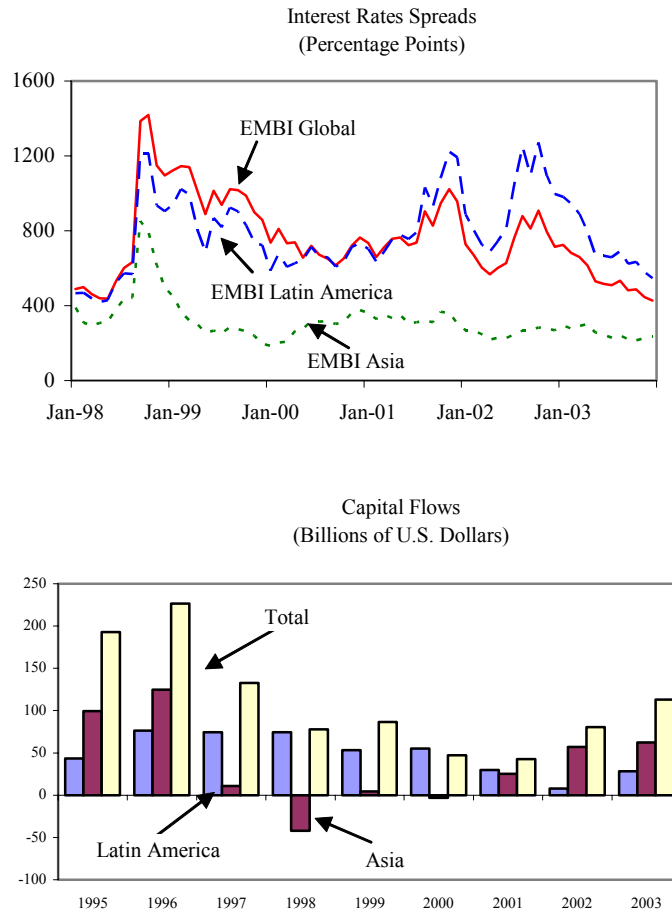

Source: J. P. Morgan and *World Economic Outlook*

V. THE ROAD AHEAD

56. GEM is part of a burgeoning new-open-economy macroeconomics literature which is rapidly transforming work in international macroeconomics and finance. The strong microeconomic foundations of the new models provide an integrated way of combining aggregate supply, aggregate demand, nominal rigidities, trade, and asset markets in a single unified theoretical framework. Using such models, policies can be evaluated more satisfactorily by analyzing changes in consumer welfare. In addition, because of the inclusion of a range of economic distortions, aggregate demand policies can have permanent effects on consumption, labor participation, and investment.

57. This approach is providing new insights on well-established policy issues such as the desirability of alternative monetary policy rules. Even more excitingly, simulations have examined questions such as the impact of increasing competition in product and labor

markets that could previously only be analyzed in conjunction with costly and time-consuming microeconomic studies. These new insights explain why a number of policy institutions are developing models based on strong microeconomic foundations. GEM is in the vanguard of multi-country policy models being built using explicit microeconomic foundations, just as MULTIMOD was one of the first such policy models to be built using rational expectations.

58. GEM is already generating useful simulations across a range of issues, but remains a project under development. In particular, the extensions discussed in Section IV of this paper will provide further depth with regard to the modeling of fiscal policy and international asset markets, including financial frictions that have such an effect on emerging markets. In addition, priority will be given to building a three-country model comprising one large industrial country plus some combination of additional industrial countries and/or emerging markets within GEM's flexible structure. Such a model would allow a wide range of issues to be examined in a unified underlying framework. At the same time, MULTIMOD will remain a useful tool for some policy work, although its use will presumably decline over time.

59. GEM will continue to have a highly flexible structure, in which the model will be adapted to the nature of the issue at hand. This flexibility is important to help provide insights as to the underlying theoretical connections and avoid the model becoming too much of a "black box". Indeed, one of the strengths of a model with strong microeconomic foundations is that it helps clarify the policy debate by ensuring that the mechanisms at work are well articulated. In addition, such flexibility also makes it easier to add new features to the model, ensuring the project remains relevant, up-to-date, and continues to garner considerable interest from the rest of the world. As an example, it would be useful to follow recent advances in academia and move away from the assumption that goods are either always traded or not to a structure in which the choice of whether to export a product depends on transportation costs and other characteristics of the good. In particular, such an extension would allow the examination of macroeconomic issues associated with trade reforms. More generally, GEM development will continue to be driven by developments in the broader literature and issues confronting the Fund.

60. A concerted effort is being made to make the model accessible to those inside and outside of the Fund. GEM is a large and complex model, and inevitably it will require an effort for people to learn how to use it. Significant resources have been put into simplifying the software used to generate GEM simulations. The modeling group has already provided training to a group of Fund economists, including several in area departments which will help integrate the model with bilateral surveillance activities. Encouragingly, a number of the economists being hired at the Fund have used new open economy models in their doctoral work, and hence have a relatively strong background in model use. Outside of the Fund, once the GEM's structure has stabilized and its properties been more fully investigated, the code and programs to run it will be provided free to those who wish to use the model. This approach was used successfully with MULTIMOD, in that a range of outside groups used the model for analysis.

61. Given that GEM remains a project under development, it is difficult to look too far into the future. Two things, however, can be said about the future with some certainty. First, the new-open-economy macroeconomy literature will continue to expand rapidly. Second,

GEM provides a vehicle for absorbing relevant insights from this literature into the Fund, as well as encouraging mutually beneficial interactions between the academic and policy communities.

ISSUES FOR DISCUSSION

62. Directors may find the seminar associated with this paper to be a useful opportunity to discuss the role of large policy models in the Fund. In particular, given the detailed knowledge of countries associated with individual desks, do Directors agree that such models are most useful for simulations exercises rather than forecasting work? Is the highly flexible structure embodied in GEM an appropriate way of approaching this task? Is the plan to provide GEM to the outside world on an open platform a sensible one? Do Directors agree that MULTIMOD should continue to be used over the next few years as GEM is further developed? Are the priorities for such development outlined in the paper—focusing on fiscal issues and asset markets, a flexible three-country model, and outreach to the rest of the Fund—appropriate?

References

- Altig, D., L. Christiano, M. Eichenbaum, and J. Linde, 2003, "Technology Shocks and Aggregate Fluctuations," preliminary working paper.
- Balassa, Bela, 1964, "The Purchasing-Power Parity Doctrine: A Reappraisal," *Journal of Political Economy* Vol. 72, pp. 584–96.
- Bayoumi, Tamim, Douglas Laxton, and Paolo Pesenti, 2003, "When Learner Isn't Meaner: Measuring Benefits and Spillovers of Greater Competition in Europe," unpublished manuscript, International Monetary Fund.
- Bernanke, Ben, Mark Gertler, and Simon Gilchrist, 1999, "The Financial Accelerator in a Quantitative Business Cycle," *Handbooks in Economics*, (Amsterdam; New York, and Oxford: Elsevier Science, North-Holland).
- Christiano, Lawrence J., Martin Eichenbaum, and Charles Evans, 2001, "Nominal Rigidities and the Dynamic Effects of a Shock to Monetary Policy," NBER Working Paper No. 8403.
- Corsetti, G., L. Dedola, 2002, "Macroeconomics of International Price Discrimination," Working Paper, University of Rome III and Bank of Italy.
- Dornbusch, Rudiger, 1976, "Expectations and Exchange Rate Dynamics," *Journal of Political Economy*, Vol. 84, No. 6, pp. 1161–76.
- Erceg, C., L. Guerrieri, and C. Gust, 2003, "SIGMA: A New Open Economy Model for Policy Analysis," Draft Paper Prepared for the Annual Central Bank Modelers' Workshop in Amsterdam.
- Fleming, J. Marcus, 1962, "Domestic Financial Policies Under Fixed and Under Floating Exchange Rates," *IMF Staff Papers*, Vol. 9, pp. 369–79 (Washington: International Monetary Fund).
- Galí, J., M. Gertler, and J. D. López-Salido, 2002, "Markups, Gaps, and the Welfare Costs of Business Fluctuations," NBER Working Paper No. 8850.
- Hall, Robert E., 1978, "Stochastic Implications of the Life Cycle-Permanent Income Hypothesis: Theory and Evidence," *Journal of Political Economy*, Vol. 86, No. 6, pp. 971–87.
- Hart, Oliver and John Moore, 1994, "A Theory of Debt Based on the Inalienability of Human Capital," *Quarterly Journal of Economics*, Vol. 109, No. 4, pp. 841–79.
- Hunt and Rebucci, 2003, "The U.S. Dollar and the Trade Deficit: What Accounts for the Late 1990s?," IMF Working Paper No. 03/194.
- International Monetary Fund, 2000, "The Impact of Higher Oil Prices on the Global Economy," (Washington). Available via the Internet:

- <http://www.imf.org/external/pubs/ft/oil/2000/oilrep.pdf>
- , 2001, “Business Cycle Linkages Among Major Advanced Economies,” *World Economic Outlook October 2001* (Washington).
- , 2003, “How Concerned Should Developing Countries Be About G-3 Exchange Rate Volatility?” *World Economic Outlook September 2003* (Washington).
- Kollman, R., 2002, “Monetary Policy Rules in the Open Economy: Effects on Welfare and Business Cycles,” CEPR Discussion Paper No. 3279.
- Kydland, Finn E., and Edward C. Prescott, 1982, “Time to Build and Aggregate Fluctuations,” *Econometrica*, Vol. 50, No. 6 pp. 1345–70.
- Lane, Philip, 2001, “The New Open Economy Macroeconomics: A Survey,” *Journal of International Economics*, 54, pp. 235–266.
- Laxton, Douglas, and Paolo Pesenti, 2003, “Monetary Rules for Small, Open, Emerging Economies,” *Journal of Monetary Economics*, Vol. 50, No. 5, pp. 1109–46.
- Lucas, Robert E., Jr., 1976, “Econometric Policy Evaluation: A Critique,” *Journal of Monetary Economics*, Vol. 1, No. 2, pp. 19–46.
- Masson, Paul, Steven Symansky, and Guy Meredith, 1990, *MULTIMOD Mark II: A Revised and Extended Model*, Occasional Paper No. 71 (Washington: International Monetary Fund).
- Mendoza, Enrique G., 1991, “Real Business Cycles in a Small Open Economy,” *American Economic Review*, Vol. 81, No. 4, pp. 797–818.
- Mundell, Robert A., 1963, “Capital Mobility and Stabilization Policy under Fixed and Flexible Exchange Rates,” *Canadian Journal of Economics and Political Science*, Vol. 29 pp. 475–85.
- Muth, J.F., 1961, Rational Expectations and the Theory of Price Movements, *Econometrica*, Vol. 29, pp. 315–35.
- Obstfeld, Maurice, and Kenneth Rogoff, 1995, “Exchange Rate Dynamics Redux,” *Journal of Political Economy*, Vol. 103, pp. 624–60.
- Obstfeld, Maurice, 2001, “International Macroeconomics: Beyond the Mundell-Fleming Model,” *IMF Staff Papers*, Vol. 47, pp. 1–39 (Washington: International Monetary Fund).
- Organization of Economic Corporation and Development, 1997, *The OECD Report on Regulatory Reform, Volume II: Thematic Studies* (Paris: Organization for Economic Cooperation and Development).

Samuelson, Paul A., 1964, "Theoretical Notes on Trade Problems," *Review of Economics and Statistics*, Vol. 46, pp. 145–54.

Smets, F., and R. Wouters, 2002, "An Estimated Stochastic Dynamic General Equilibrium Model of the Euro Area," ECB Working Paper No. 171.

Taylor, John, 1993, "Discretion versus Policy Rules in Practice," *Carnegie-Rochester Conference Series on Public Policy* 39, pp. 195–214.